

Installation and Operation Manual



MOUNTAIN SERIES

Stone Hearth Oven

*Radiant Flame, Underfloor Infrared (IR) Burner,
Gas-Fired, Gas/Wood Combination Models*

MT. CHUCKANUT WS-MS-4-RFG-IR-(W)

MT. ADAMS WS-MS-5-RFG-IR-(W)

MT. BAKER WS-MS-6-RFG-IR-(W)

MT. RAINIER WS-MS-7-RFG-IR-(W)

Wood Stone

WOOD STONE CORPORATION

1801 W. Bakerview Rd.
Bellingham, WA 98226 USA

Toll Free 800.988.8103

Tel 360.650.1111

Fax 360.650.1166



TABLE OF CONTENTS

Mountain Series RFG-IR-W 3
Cautions & Warnings 4
Unloading & Moving the Oven 6
Installation Clearances 7
Facade Details 9
Outdoor Installations 10
Gas Specifications 11
Electrical Specifications 13
Venting 14
Flue Adapter, MS-5, 6, 7 17
Flue Adapter, MS-4 18
Venting Do's & Don'ts 19
Assembly 27
Mantle Mounting 28
Front Panel Assembly 29
Extension Panel Assembly 30
Stucco Application 32
Controller 33
Initial Start-Up 34
Daily Operation 35
Flame Height Control 36
Maintenance & Cleaning 37
Use of Wood in the Oven 38
Managing the Oven Fire 39
Wood Safety Considerations 40
Fuelwood Facts 41
Troubleshooting Guide 42
Operation Sequence 43
120 VAC Electrical Diagram 44
240 VAC Electrical Diagram 45
Interlock Diagram 46
Limited Warranty 47



**INSTALLATION AND OPERATION MANUAL
THE WOOD STONE MOUNTAIN SERIES**

**STONE HEARTH COOKING EQUIPMENT
WS-MS-(4,5,6,7)-RFG-IR-W-(NG,LP,HLP) MODELS
GAS-FIRED, WOOD OPTIONAL OVEN**

ADDITIONAL COPIES AVAILABLE UPON REQUEST

**WOOD STONE MOUNTAIN SERIES RFG-IR-(W) OVEN
INSTALLATION AND OPERATING INSTRUCTIONS****RETAIN THIS MANUAL FOR FUTURE REFERENCE**Additional copies of this manual at woodstone-corp.com.

For prompt responses to service/maintenance questions, call us at @ 1-800-988-8103.

READ ALL INSTRUCTIONS BEFORE INSTALLING AND USING THIS APPLIANCE

Please read this entire manual before you install the oven. Failure to follow instructions may result in property damage, bodily injury or even death. Contact your local building or fire officials about restrictions and installation inspection in your area.

IMPORTANT: Consult your local gas supplier for a statement outlining a procedure to be followed in the event you smell gas. Post the statement in a prominent location.

WHEN THE OVEN IS NOT PROPERLY INSTALLED, A FIRE MAY RESULT.
TO REDUCE RISK OF FIRE, FOLLOW THE INSTALLATION INSTRUCTION.

FOR YOUR SAFETY: Do not store or use gasoline or other flammable vapors or liquids in the vicinity of this or any other appliance.

POUR VOTRE SÉCURITÉ: Ne pas entreposer ni utiliser d'essence ou d'autres vapeurs de liquides inflammables ou des liquides dans les environs de ce ou de tout autre appareil.

Always keep the area under and around this appliance free and clear of any and all combustible materials.

CAUTION: Never use gasoline, gasoline-type lantern fuel, kerosene, charcoal lighter fluid or similar liquids to start or freshen-up a fire in this oven. Keep all such liquids well away from the oven when in use.

IN THE EVENT OF A POWER FAILURE, NO ATTEMPT SHOULD BE MADE TO OPERATE THE OVEN.

IMPORTANT: It is recommended that this oven be installed, maintained and serviced by authorized professionals.

**USE SOLID WOOD FUEL ONLY
DO NOT USE PRODUCTS NOT SPECIFIED FOR USE WITH THIS OVEN**



A MAJOR CAUSE OF OVEN RELATED FIRES IS A FAILURE TO MAINTAIN REQUIRED CLEARANCES TO COMBUSTIBLE MATERIAL. IT IS OF UTMOST IMPORTANCE THAT THIS OVEN BE INSTALLED ONLY IN ACCORDANCE WITH THESE INSTRUCTIONS.

DO NOT OVER-FIRE THIS OVEN. IF FLAMES ARE SPILLING OUT OF THE DOOR OPENING, OR IF OVEN FLOOR TEMPERATURE EXCEEDS 850 °F, THEN YOU ARE OVER-FIRING THE OVEN.

CAUTION: DISCONNECT POWER TO THE OVEN BEFORE SERVICING OR CLEANING.

WARNING: Improper installation, adjustment, alteration, service or maintenance can result in property damage, injury or death. Read the installation, operation and maintenance instructions thoroughly before installing or servicing this equipment.

AVERTISSEMENT: L'installation, le réglage, la modification, la réparation ou l'entretien incorrect de cet appareil peut causer des dommages matériels, de blessures ou la mort. Lire attentivement les instructions d'installation, de fonctionnement et d'entretien avant de procéder à son installation ou entretien.

This product must be installed by a licensed plumber or gas fitter when installed within the Commonwealth of Massachusetts.

SAVE THE INSTRUCTIONS

Wood Stone ovens
have been tested and approved by Intertek Testing Services and
conform to ANSI Z83.11, UL 2162, UL 737 and CGA 2.17;
are certified to CSA 1.8, ULC/ORD 2162 and ULC S627;
and to NSF/ANSI 4.



Intertek
ANSI Z83.11
CSA 1.8



Intertek
ANSI/NSF 4



USING A FORKLIFT

Use a forklift with adequate fork lengths and lifting capacity. If necessary, fork Extensions must be used so the Forks extend through the fork lift pockets to the opposite side of the stand. Lift from either side as shown in figure a. Do not lift from the front or back. The oven is very top heavy, so spread the forks as far apart as possible.

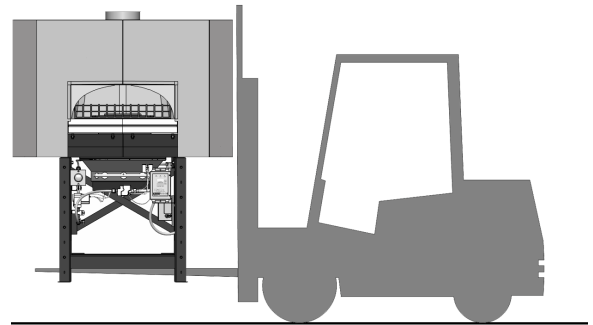

fig. a

⚠ WARNING Minimum Required Forklift Capacities

Model	Oven	Approximate shipping weight	Minimum fork length required	Required forklift capacity
WS-MS-4	Mt. Chuckanut	2,400 lbs.	4'	5,000 lbs.
WS-MS-5	Mt. Adams	3,600 lbs.	5'	6,000 lbs.
WS-MS-6	Mt. Baker	4,600 lbs.	6'	8,000 lbs.
WS-MS-7	Mt. Rainier	6,000 lbs.	7'	12,000 lbs.

USING A PALLET JACK

Once the oven has been removed from the delivery vehicle, it can easily be moved on smooth, flat surfaces using a Pallet Jack. To lift the oven with a Pallet Jack, remove the front and rear angle iron stabilizers from the base of the oven stand and place a stout 4x4 post through the Fork Pocket as shown in figure b.

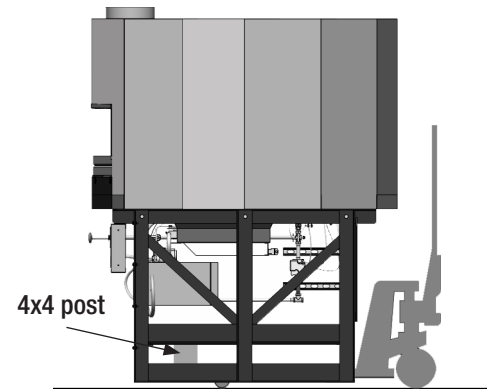

fig. b

THE OVEN IS VERY TOP-HEAVY. MOVING THE OVEN UP OR DOWN A RAMP OR INCLINE ON A PALLET JACK IS NOT SAFE!

USING A CRANE

The oven arrives with four lifting eyes attached. When craning a Wood Stone oven, use a spreader bar with a two-legged sling rigged on each end. The spreader bar should be of a sufficient length to keep the sling from contacting the oven. See figure c.

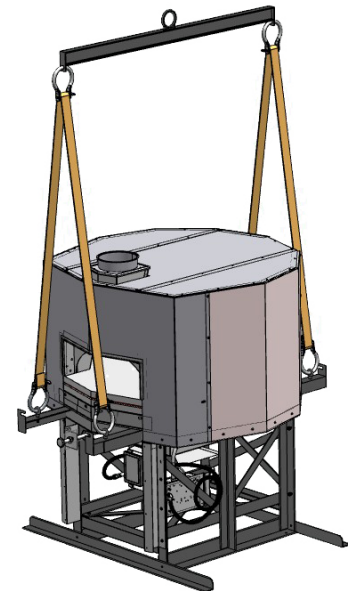

fig. c

DO NOT TURN THE OVEN ON ITS SIDE!

Contact Wood Stone if the oven must be turned on its side for specific instructions. Moving a Wood Stone oven can present challenges to even the most experienced riggers. Take your time, use your head, secure the proper equipment and make safety your first priority. Please don't hesitate to call the factory for technical support.

DELIVERY NOTE: The customer will receive an Oven Shipping Notification when the oven leaves the Wood Stone factory. This will include a PRO# and a trucking company contact number. Wood Stone recommends that you confirm the delivery date/time with the trucking company before committing to heavy equipment and/or labor. Our goal is a smooth and safe delivery.



CLEARANCES

1. The Wood Stone Mountain Series oven must have a minimum 1-inch clearance to combustibles from all sides, and 6-inch clearance to combustibles from the top (see INSTALLATION CLEARANCES section on next page). If building materials will contact the oven, they must be completely non-combustible. Please note that standard Drywall (or Sheetrock) is considered a combustible. When non-combustible building materials contact the body of the oven, the respective clearances are transferred to those non-combustibles.
2. Any facade 6 inches to either side of the oven doorway or above, must be constructed of non-combustible building materials.
3. **For gas/wood combination models**, this oven is suitable for installation on combustible floors (convient à l'installation sur un plancher combustible). The minimum hearth extension area to be covered with a non-combustible floor surface must extend 36 inches in front of and 30 inches to either side of the oven door opening.

NOTICE: For stucco-ready appliances (model numbers including an "S"), the same clearances as described above apply. Non-combustible stucco mix must be used and applied to a minimum thickness of 1".

The floor design and construction must be adequate to handle the weight of the oven. See woodstone-corp.com for floor loading information.

IF THIS OVEN IS NOT PROPERLY INSTALLED A FIRE MAY RESULT. TO REDUCE THE RISK OF FIRE, FOLLOW THESE INSTALLATION INSTRUCTIONS. A MAJOR CAUSE OF OVEN RELATED FIRES IS FAILURE TO MAINTAIN REQUIRED CLEARANCES (AIR SPACES) TO COMBUSTIBLE MATERIALS. IT IS OF UTMOST IMPORTANCE THAT THIS OVEN BE INSTALLED ONLY IN ACCORDANCE WITH THESE INSTRUCTIONS.

WARNING: DO NOT PACK REQUIRED AIR SPACES WITH INSULATION OR OTHER MATERIAL.



WARNING: Installation and servicing of this product could expose you to glasswool/ceramic fibers as well as calcium silicate dust. **ALWAYS WEAR RESPIRATORY AND EYE PROTECTION WHEN INSTALLING OR SERVICING THIS APPLIANCE.** Please read this entire manual before you install the oven. Failure to follow instructions may result in property damage, bodily injury or even death. Contact your local building or fire officials about restrictions and installation inspection in your area.

PLEASE READ THIS ENTIRE MANUAL BEFORE YOU INSTALL THE OVEN. FAILURE TO FOLLOW INSTRUCTIONS MAY RESULT IN PROPERTY DAMAGE, BODILY INJURY OR EVEN DEATH. CONTACT YOUR LOCAL BUILDING OR FIRE OFFICIALS ABOUT RESTRICTIONS AND INSTALLATION INSPECTION IN YOUR AREA.



**THE FOLLOWING CLEARANCE INFORMATION APPLIES TO ALL
WOOD STONE MOUNTAIN SERIES OVENS**

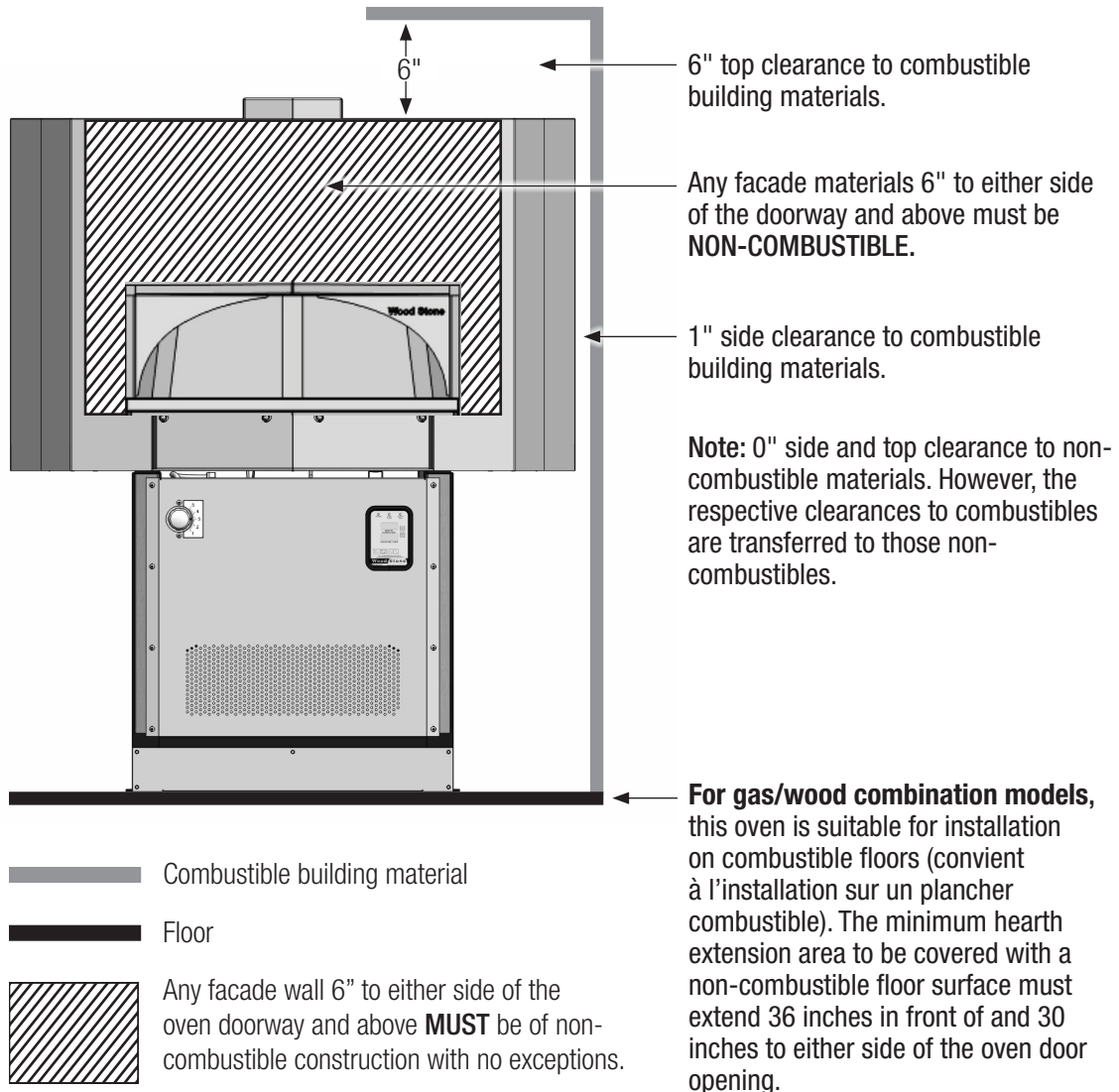



Wood Stone Mountain Series (MS-) ovens carry an ETL Sanitation listing. The oven interior only is ETL listed to NSF/ANSI Standard 4. This means that the surfaces of the oven which are meant to be left exposed after the facade has been put in place have been evaluated from the standpoint of sanitation and food safety and found to comply with NSF/ANSI Standard 4. To operate the oven in accordance with NSF/ANSI Standard 4, only pizza and bread products may be cooked directly on the floor of the oven. Other types of food may be cooked on or in pans, or other suitable containers to prevent spillage onto the oven deck.

Go to www.woodstone-corp.com for detailed instructions for constructing a facade around a Wood Stone oven.

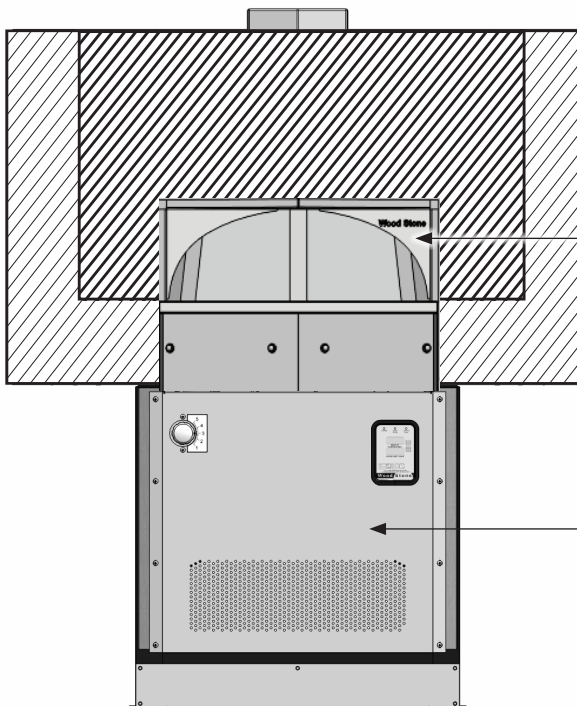



If using an exhaust hood over the oven, make sure your facade allows proper access for removal of the hood filters.

**Oven Arches
DO NOT REMOVE**

Removal will affect structural integrity, heat retention, operation and **void the Warranty**.

A removable Service Panel or storage box allows access for service of gas and electrical components. If this panel is not used, access and air intake of equivalent dimensions **MUST** be provided at the front of the oven.

 Hatched areas shall not be exposed after installation of facade.

 Any facade wall 6" to either side of the oven doorway and above **MUST** be of non-combustible construction with no exceptions.



OUTDOOR INSTALLATIONS

The Mountain Series (MS-) model ovens are ETL approved for outdoor installation. When installed outdoors, the open area beneath the oven must be enclosed, with the exception of the perforated area on the front Service Panel (or storage box) for air intake. The oven may be installed in a weatherproof enclosure. If so be sure to maintain all clearances and adhere to the installation requirements included in this manual.

KEEP THE AREA AROUND AND BENEATH THE OVEN CLEAR OF GRASS, LEAVES AND OTHER COMBUSTIBLE MATERIALS.

Wood Stone also offers the following options to enclose the area beneath the oven.

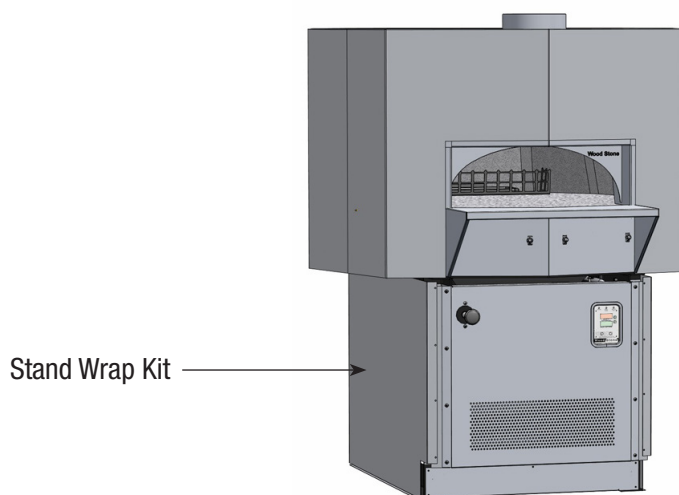
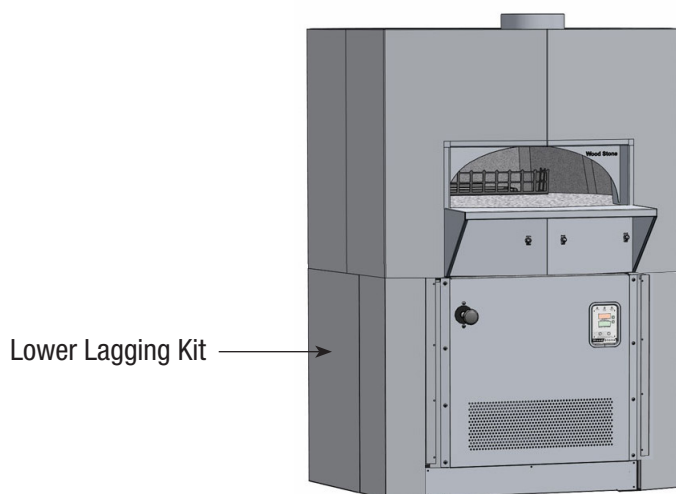



FACTORY SPECIFIED INDIVIDUAL BURNER MANIFOLD PRESSURES (W.C.) FOR WS-MS-RFG-IR-W MODELS

Natural Gas Equipped			Propane (LP) Equipped			Propane (HLP) Equipped		
Model	SV-1	SV-2	Model	SV-1	SV-2	Model	SV-1	SV-2
WS-MS-4-RFG-IR-NG	3.5"	5"	WS-MS-4-RFG-IR-LP	9"	7"	WS-MS-4-RFG-IR-HLP	9"	7"
WS-MS-5-RFG-IR-NG	3.5"	4.75"	WS-MS-5-RFG-IR-LP	9"	8"	WS-MS-5-RFG-IR-HLP	9"	8"
WS-MS-6-RFG-IR-NG	3.5"	4.75"	WS-MS-6-RFG-IR-LP	9"	8"	WS-MS-6-RFG-IR-HLP	9"	8"
WS-MS-7-RFG-IR-NG	3.5"	4.6"	WS-MS-7-RFG-IR-LP	9.2"	9.5"	WS-MS-7-RFG-IR-HLP	9.2"	9.5"

This oven requires no modifications or adjustments for use at high altitudes.

The installation must conform with local codes, or in the absence of local codes with the National Fuel Gas Code, ANSI 223.1 or the Natural Gas Installation Code, CAN/CGA-B149.1, as applicable.

SV-1 is the gas control valve that operates the Underfloor Infrared (IR) Burner. The manifold pressure is checked at the outlet port on the SV-1 gas valve.

SV-2 is the gas control valve that operates the interior Radiant Burner. SV-2 is located at the rear left beneath the oven. The manifold pressure test port for the Radiant Burner is a 1/8" NPT plugged tap located at the base of the T-junction between the SV-2 and the Radiant Burner.

The burner manifold pressure has been adjusted and tested at the factory. A variety of factors can influence this pressure, so be sure to test the burner manifold pressure and adjust the valve as necessary to achieve the specified pressure.

NOTE: The gas valve is shipped in the **ON** position.

GAS CONNECTION

Mountain Series ovens are equipped with a 3/4" NPT gas connection located at the rear left of the oven. Have a licensed gas installer provide the hook-up and test all fittings and pipe connections for leaks. Use approved gas leak detectors (soap solutions or equivalent) over and around the fittings and pipe connections. **DO NOT USE FLAME TO TEST FOR LEAKS.**

All gas piping up to the oven must have a minimum inside diameter of 3/4", including all fittings and shut off valves, which should be of the full flow type.

Wood Stone recommends that the appliance's individual shutoff valve (supplied by others) be left readily accessible. Wood Stone also recommends that inspection and maintenance of the burner and gas piping connections of this appliance be performed at regularly scheduled intervals and only by professional gas appliance service agencies.

Maximum inlet gas pressure must not exceed 14" W.C. (1/2 psi)



MAXIMUM HOURLY BTU INPUT RATES FOR WS-MS-RFG-IR-W MODELS

Natural Gas Equipped		Propane (LP) Equipped		Propane (HLP) Equipped	
Model	BTU/hr Input Rate	Model	BTU/hr Input Rate	Model	BTU/hr Input Rate
MS-4-RFG-IR-W-NG	115,000	MS-4-RFG-IR-W-LP	102,000	MS-4-RFG-IR-W-HLP	115,000
MS-5-RFG-IR-W-NG	188,000	MS-5-RFG-IR-W-LP	159,000	MS-5-RFG-IR-W-HLP	188,000
MS-6-RFG-IR-W-NG	188,000	MS-6-RFG-IR-W-LP	159,000	MS-6-RFG-IR-W-HLP	188,000
MS-6-RFG-IR-NAP-W-NG	218,330	MS-6-RFG-IR-NAP-W-LP	218,330	MS-6-RFG-IR-NAP-W-HLP	218,330
MS-7-RFG-IR-W-NG	220,000	MS-7-RFG-IR-W-LP	227,000	MS-7-RFG-IR-W-HLP	227,000

GAS INLET PRESSURE

For ovens running on natural gas, an inlet pressure of 7 to 10" W.C. is recommended to ensure optimum oven performance. Incoming gas pressure below this range will affect oven performance, the lower the pressure the greater the negative impact. If the gas supply pressure is greater than 14" W.C. (1/2 psi), an external regulator, supplied by others, is REQUIRED to lower the gas pressure to the acceptable range. Issues caused by low or high gas pressure are installation issues, and will not be covered under the Warranty.

For ovens running on Propane (LP or HLP), the recommended inlet pressure to ensure optimum oven performance is 10 to 12" W.C. Incoming gas pressure below this range will affect oven performance, the lower the pressure the greater the negative impact. If the gas supply pressure is greater than 14" W.C. (1/2 psi), an external regulator, supplied by others, is REQUIRED to lower the gas pressure to the acceptable range. Issues caused by low or high gas pressure are installation issues, and will not be covered under the Warranty.

For all installations, follow best practices for proper gas line pipe sizing for the line serving the oven. To ensure proper operation, all gas piping and fittings leading up to the oven should have an inside diameter equal to or greater than that of the oven gas connection. Also make sure that a readily accessible shut off valve (supplied by others) is installed near the oven, and in accordance with all applicable codes. Shut off valves must be of the full-flow type, and not introduce any restriction into the gas line.

The connection to the oven should be hard-piped whenever feasible. If this is not possible, use a properly sized flexible connector approved for this application. When using a flexible connector make sure that its design does not present any reduction in pipe diameter or other restriction. Oven issues caused by improper pipe sizing, improper shut off valves, restrictive connectors, or any other deficiency in the gas supply design or installation will not be covered under the oven warranty.

GAS CODE LIMITATIONS

The installation of this appliance must conform with local codes, or in the absence of local codes, with the National Fuel Gas Code, ANSI Z223.1 or The Natural Gas Installation Code CAN/CGA-B149.1 as applicable.

The appliance and its individual shutoff valve (supplied by others) must be disconnected from the gas supply piping system during any pressure testing of that system at test pressures in excess of 1/2 psi (3.45 kPa).

The appliance must be isolated from the gas supply piping system by closing its individual manual shutoff valve (supplied by others) during any pressure testing of the gas supply piping system at test pressure, equal to or less than 1/2 psi (3.45 kPa).



Incoming power should be connected to the terminal strip located in the Transformer Junction Box beneath the oven (see diagram below). The standard oven model comes configured for connection to a 120 VAC circuit. The oven can be ordered configured for connection to a 240 VAC circuit. Always refer to the equipment data plate beneath the oven to verify the proper voltage. The voltage is also specified on the Transformer Box cover. Never connect an oven rated 120 VAC to a 240 VAC circuit or vice versa.

It is recommended that the oven be connected to its own individual branch circuit. Have a license electrician connect the oven to the appropriate 120 VAC or 240 VAC circuit.

Electrical diagrams are located directly to the right, behind the removable service/intake panel of the appliance as well as inside the control box. Electrical diagrams are also located near the end of this manual.

ELECTRICAL RATINGS

120 VAC, 1.1 A, 50/60 Hz

240 VAC, 1.1 A, 50/60 Hz

ELECTRICAL CODE LIMITATIONS

Electrical grounding: This appliance must be electrically grounded in accordance with local codes, or in the absence of local codes, with the National Electrical code, ANSI/NFPA 70 or the Canadian Electrical Code, CSA C22.2 as applicable.

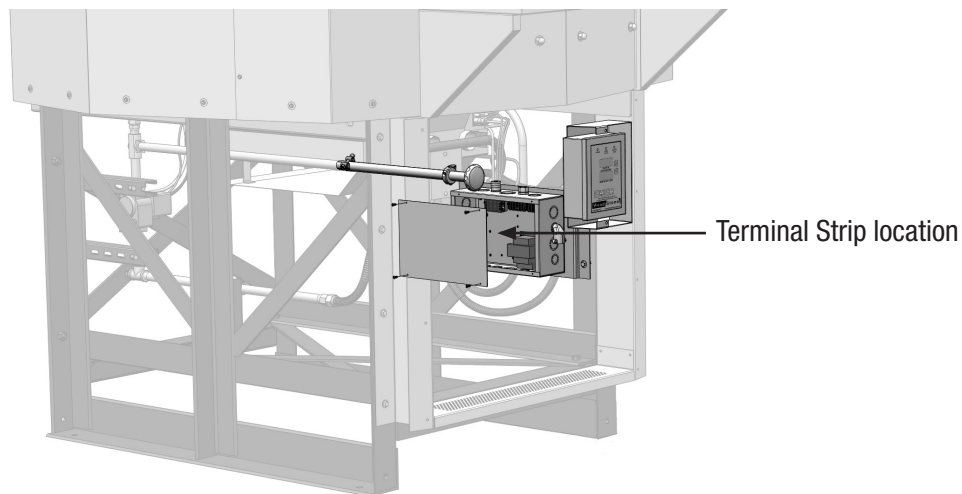



THIS MODEL MUST BE VENTED AS A SOLID FUEL APPLIANCE

The following are the manufacturer's recommendations for venting the Wood Stone MS (Mountain Series) RFG-IR-W ovens. It is never appropriate to use "B vent" in any part of an exhaust system connected to a Wood Stone oven. All duct material must be manufactured to the specifications of a grease duct. This is a wood/gas combination oven and must be vented as a solid fuel piece of equipment. Due to the possibility of sparks entering the system, exhaust systems serving solid fuel equipment must be vented separately from other non-solid fuel equipment. The duct serving this oven should be inspected at least twice a month during the first two months of operation, to establish rate of creosote buildup and necessary cleaning schedule. Submit your venting plans to your local authorities before proceeding with your installation, as there may be additional requirements in your area.

Wood Stone recommends cleaning and inspection at least monthly on any ventilation system serving solid fuel equipment.

There are two venting options:

VENTING OPTION 1

Direct Connection: A listed building heating appliance chimney, also listed as a grease duct as described in NFPA 96, connected directly to the oven flue collar and provided with a power ventilator listed for restaurant appliance exhaust. The power ventilator should be rated for a minimum of 450 °F. Wood Stone does not recommend the use of an in-line fan. A field built grease duct, constructed and installed to the specifications of a grease duct as detailed in NFPA 96 or the International Mechanical Code, may also be used.

A static pressure of -0.14 inches water column is necessary at the oven flue collar to ensure that flue gas temperatures do not exceed 450 °F at the fan inlet. This measurement may be taken by inserting the probe of the magnahelic gauge through the oven doorway, upwards to the oven flue collar. **NOTE:** Double door ovens (models ending in -DD), have two flue collars, both must be connected and a static pressure of -0.14 inches must be maintained at each collar. See table below for CFM required to attain the specified static pressure. **NOTE:** Solid fuel burning ovens must be vented separately from non-solid fuel burning equipment.

CFM REQUIREMENTS (DIRECT CONNECT)

Model	CFM required
WS-MS-4-RFG-IR-W	425
WS-MS-5-RFG-IR-W	500
WS-MS-6-RFG-IR-W	500
WS-MS-7-RFG-IR-W	550

Install the venting system in accordance with the duct manufacturer's instructions and in accordance with all local codes. All field built components should be built to the applicable codes and standards and are subject to the approval of the authority having jurisdiction.



NOTE: Mountain Series ovens (MS-5, MS-6 and MS-7) intended for direct connection will have a round flue adapter already installed at the factory to facilitate direct connection to a round duct. If the oven is to be installed under a hood, it WILL be necessary to remove the round adapter to properly position the hood and ensure proper flue gas ventilation. This is done by removing the screws that attach the adapter to the oven.

The MS-4 will have a round flue adapter supplied in a separate box. It should ONLY be installed with direct connect installations. DO NOT install if the oven is installed under an exhaust hood.

Instructions are included in the manual. Please contact Wood Stone if you have any questions.

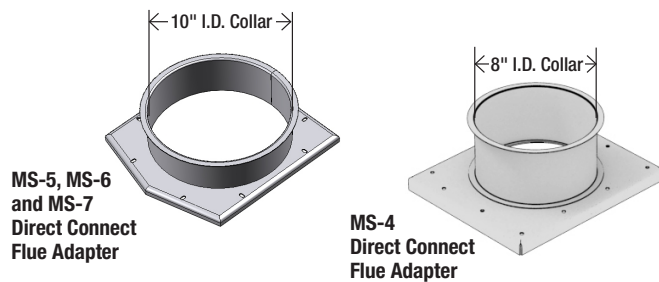

Model	Oven	Flue Collar I.D. (nominal)
WS-MS-4	Mt. Chuckanut	8 inch
WS-MS-5	Mt. Adams	10 inch
WS-MS-6	Mt. Baker	
WS-MS-7	Mt. Rainier	

NOTE: The round collar flue adapter is for direct connection installations ONLY. This adapter should NOT be used with an exhaust hood.

VENTING OPTION 2

A Listed Type 1 exhaust hood or one that is constructed and installed in accordance with all relevant local and national codes. Wood Stone offers eyebrow-type hoods designed specifically for Wood Stone ovens. See specification sheet on hoods for Wood Stone ovens. Note that the notch of the hood is even with the front edge of the oven. The hood should be installed in accordance with the hood manufacturer's instructions, and with the Standard for Ventilation Control and Fire Protection of Commercial Cooking Operations, NFPA 96 and/or the applicable local and national codes. Solid fuel burning ovens must be vented separately from non-solid fuel burning equipment.

It is never appropriate to use "B vent" in any part of an exhaust system connected to a Wood Stone oven. All duct material must be manufactured to the specifications of a grease duct. Due to the possibility of sparks entering the duct, exhaust systems serving solid fuel equipment **MUST** not be combined with exhaust systems serving other (non-solid fuel) equipment. This model is rated as solid fuel equipment and must be vented as such.

VERY IMPORTANT!

WOOD STONE RECOMMENDS THAT YOU CONSULT WITH A QUALIFIED MECHANICAL ENGINEER AND SUBMIT YOUR VENTING PLANS TO LOCAL CODE AUTHORITIES BEFORE PROCEEDING WITH INSTALLATION.



FIRE SUPPRESSION

Check with your local code officials to see if fire suppression is required in your area. If fire suppression is required, you must vent the oven using a Type 1 hood constructed and installed in accordance with NFPA 96. If fire suppression is required, Wood Stone recommends providing protection for the hood duct collar and plenum. The fusible link in the hood must be rated at 450 °F minimum. Wood Stone offers Listed exhaust hoods for our ovens that are pre-piped for ANSUL R-102 fire suppression. All installations are subject to the approval of the local authority having jurisdiction.

INSTALLATION VIEWS OF A WOOD STONE HOOD

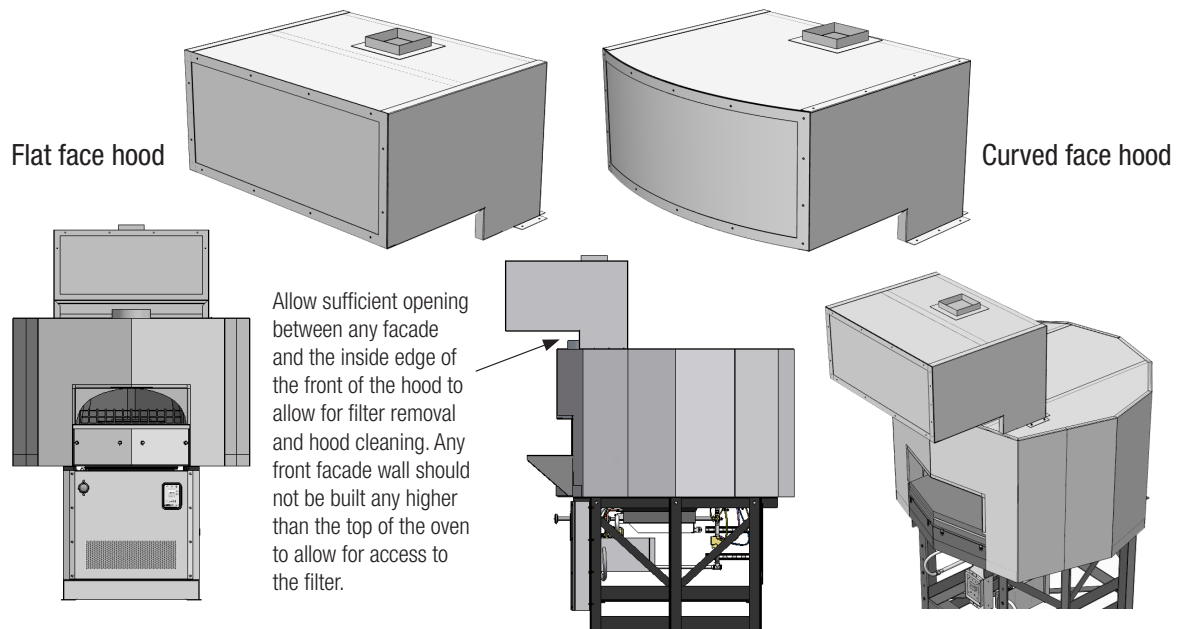



MOUNTAIN SERIES MS-5, MS-6 & MS-7 OVENS: FLUE ADAPTER INSTALLATION

The flue adapter unit is designed to facilitate connection to a round duct. Use the stainless steel screws and sealant provided to attach the flue adapter to the exhaust outlet on the oven if it is not already installed.

Note: If using a Selkirk or other modular-type duct, attach according to the manufacturer's instructions. Otherwise, the duct must be attached with a full perimeter weld. All duct must be grease-rated duct. If the oven is going to be enclosed, the flue adapter and exhaust outlet must be wrapped with an insulating material approved for use with a grease-duct.

**The flue adapter is for direct connection to a duct system ONLY.
DO NOT install if oven is installed under an exhaust hood.**

FLUE ADAPTER ATTACHED TO OVEN FLUE COLLAR

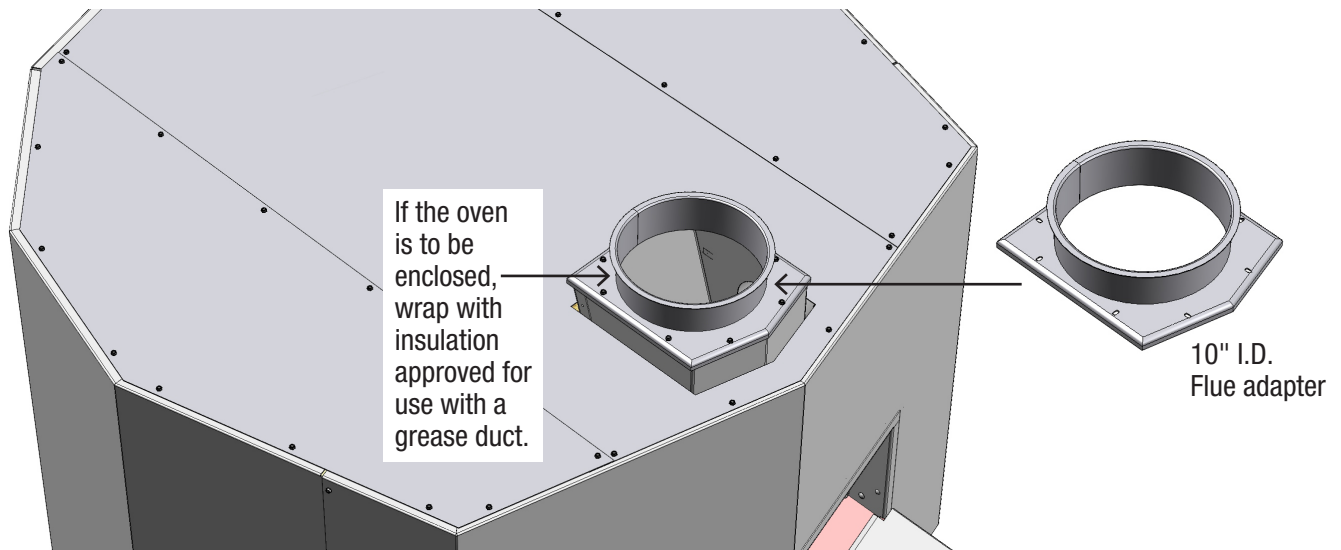

FLUE ADAPTER INSTALLATION (If not already installed)

- Apply the supplied Engineered Grade Ceramic Sealing Compound to the underside of the Flue Adapter with an unbroken bead around the perimeter, and around each individual screw hole.
- Then fasten with the supplied screws.

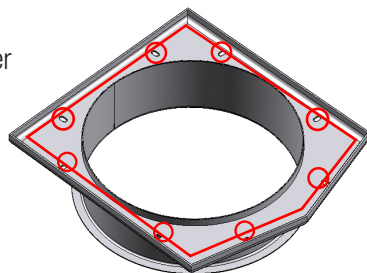

Underside of Flue Adapter showing where Ceramic Sealing Compound should be applied

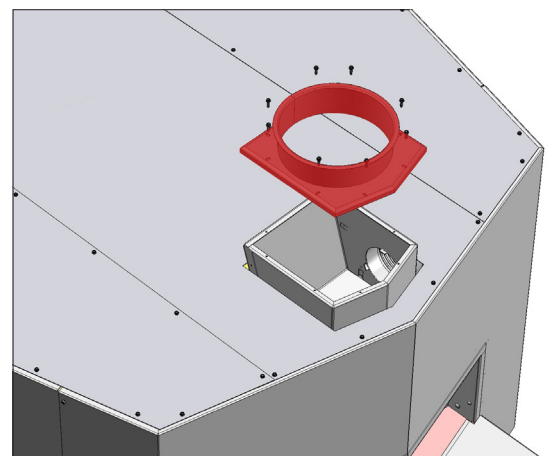



MOUNTAIN SERIES MS-4 OVENS: FLUE ADAPTER INSTALLATION

The flue adapter unit is designed to facilitate connection to a round duct. Use the provided stainless steel screws and sealant provided to attach the flue adapter (8" I.D.) to the exhaust outlet on the oven.

Note: If using a Selkirk or other modular-type duct, attach according to the manufacturer's instructions. Otherwise, the duct must be attached with a full perimeter weld. Grease-rated duct is required throughout the system. If the oven is going to be enclosed, the flue adapter and exhaust outlet must be wrapped with an insulating material approved for use with a grease-duct.

**The flue adapter is for direct connection to a duct system ONLY.
DO NOT install if oven is installed under an exhaust hood.**

FLUE ADAPTER ATTACHED TO OVEN FLUE COLLAR

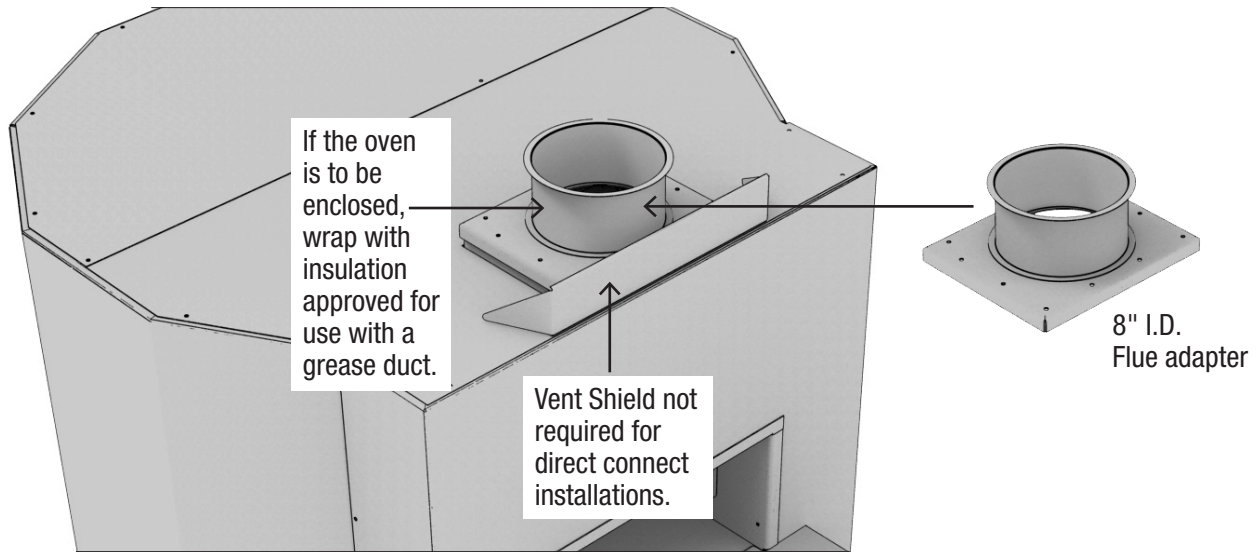

FLUE ADAPTER INSTALLATION (If not already installed)

- Apply the supplied Engineered Grade Ceramic Sealing Compound to the underside of the Flue Adapter with an unbroken bead around the perimeter, and around each individual screw hole.
- Then fasten with the supplied screws.

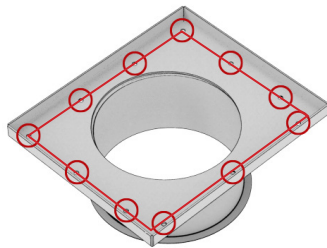

Underside of Flue Adapter showing where Ceramic Sealing Compound should be applied

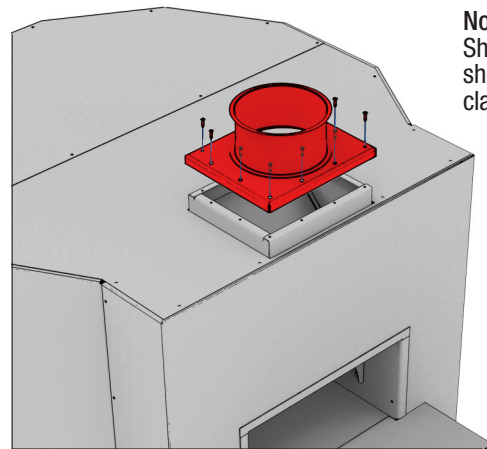

Note: Vent Shield not shown for clarity



VENTING DO'S AND DON'TS

When installing a Wood Stone Mountain Series oven there are some basic guidelines to follow regarding oven venting that will help ensure proper operation and performance of the gas burners on the oven. These guidelines will also help prevent damage to the oven's gas and electrical components due to improper venting and installation. Damage caused by improper venting and installation is not covered by the oven warranty. This information applies to all Wood Stone Mountain Series (MS) ovens equipped with one or more gas burners.

Most Wood Stone Mountain Series ovens are built into some sort of wall structure or enclosure. This creates the potential for different venting scenarios that can be detrimental to the operation and performance of the oven burners. Here are some basic rules that to follow that will ensure a properly functioning oven installation. Illustrated examples are included on the following pages.

RULE 1

The **ONLY** pathway for air to enter the space beneath the oven should be at the front of the oven at the perforated opening in the oven Service Panel provided with the oven, or on ovens equipped with an optional Storage Box, through the perforations provided on the oven Storage Box. This will eliminate the chance of air movement or cross drafts beneath the oven that can disrupt the oven burners.

RULE 2

DO NOT block the flow of air through the front Service Panel. It is required to provide necessary combustion air to the oven burners. Airflow and service access **MUST** be provided from the front of the oven only at this Service Panel. **DO NOT** relocate the oven air intake (see Rule 1).

RULE 3

To ensure proper venting of the oven, you must use an appropriate exhaust fan as described in this manual. There must also be an adequate source of make-up air provided to your kitchen space—the room that the oven opens into. The make-up air supply should not point directly at the oven. Other than the oven Service Panel, do not provide make-up air or other ventilation into an enclosure that surrounds the oven (see Rule 1). Without proper make-up air the oven, (or any gas equipment), will not vent and operate correctly.

Please review the illustrations on the following pages.



DIRECT CONNECT VENTING EXAMPLES

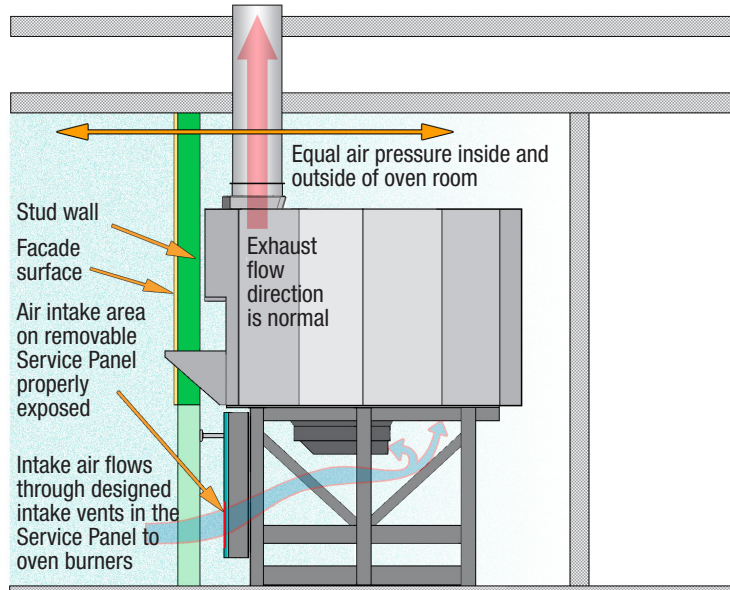

1 Acceptable venting

Example 1 shows a proper installation. The enclosure around the oven is completely sealed so that the only air entering the space beneath the oven comes through the oven Service Panel.

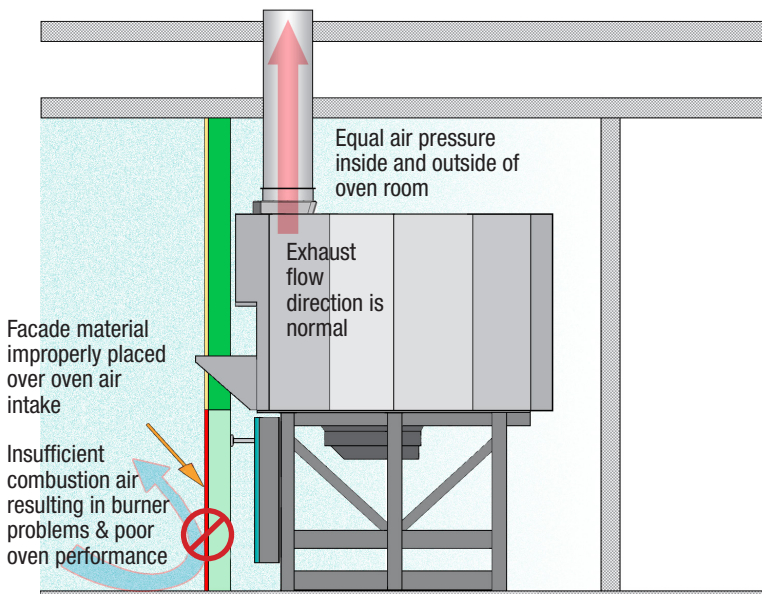

2. Unacceptable venting

Example 2 is not acceptable because the combustion air intake is blocked, preventing combustion air from reaching the oven burners. The burners will not function properly, and will lead to damage of oven components.



DIRECT CONNECT VENTING EXAMPLES

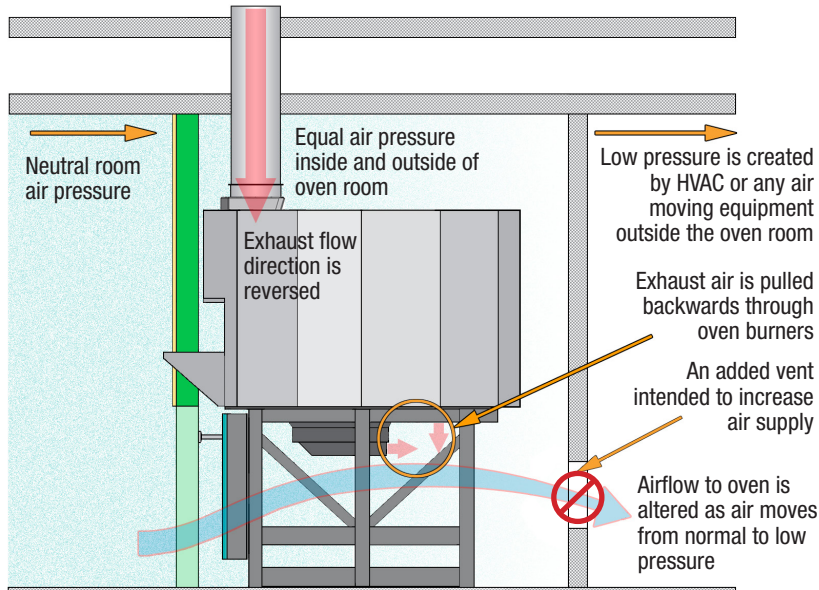

3. Unacceptable venting

Example 3 shows an incorrect installation where an additional vent was added to the wall behind the oven, creating an air pressure difference causing air movement beneath the oven and disrupting the operation of the oven burners. This air movement can be so severe as to cause a downdraft, pulling the exhaust down the oven flue and backwards through the burners, leading to heat damage of oven components.

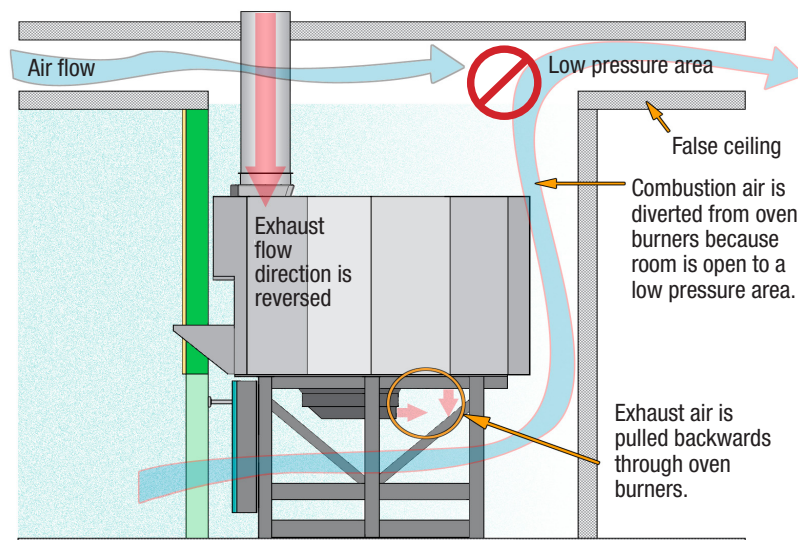

4. Unacceptable venting

Example 4 shows an incorrect installation where the enclosure surrounding the oven is open to the attic space above the ceiling. Air can move rapidly through the space enclosing the oven to the lower pressure area within the attic space. This can cause a downdraft situation at the oven, pulling air and heat backwards through the oven burners, leading to damage of oven components.



DIRECT CONNECT VENTING EXAMPLES

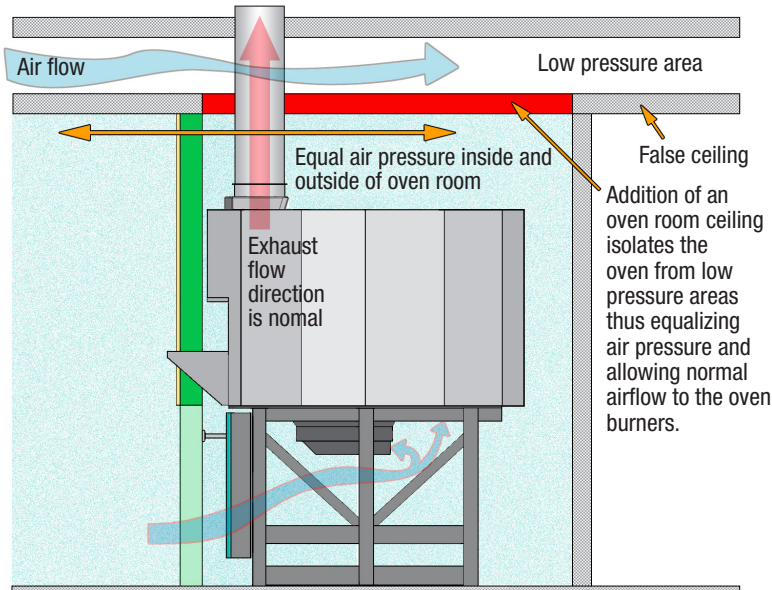

5 Acceptable venting

Example 5 shows a correct installation where a ceiling has been added to the enclosure surrounding the oven to correct an improper installation.



HOOD INSTALLATIONS

In addition to the information given for installations using the direct connect venting method, the following information applies to installations where the oven is being vented using a Listed Type 1 hood. Also refer to the OVEN VENTING section earlier in this manual.

Note: For MS-5, 6 or 7 models with round flue adapter attached, the adapter may prevent the proper positioning of the hood. The flue adapter is attached with screws which can be removed if the adapter is in the way.

1. To mount Wood Stone hood, determine the center line of the hood and place it on the oven in line with the center line of the oven **"A"**.
2. Mount hood as far forward on oven as possible—place the hood so the front edge of lower notch is even with the front of the oven **"B"**.
3. Attach hood to oven top by fastening flange with #10 x 1" self-tapping screws (supplied) **"C"**.
4. Attach grease rated duct to the outlet on the hood. The hood captures over the oven flue collar and oven doorway. No connection is made to the oven flue collar.

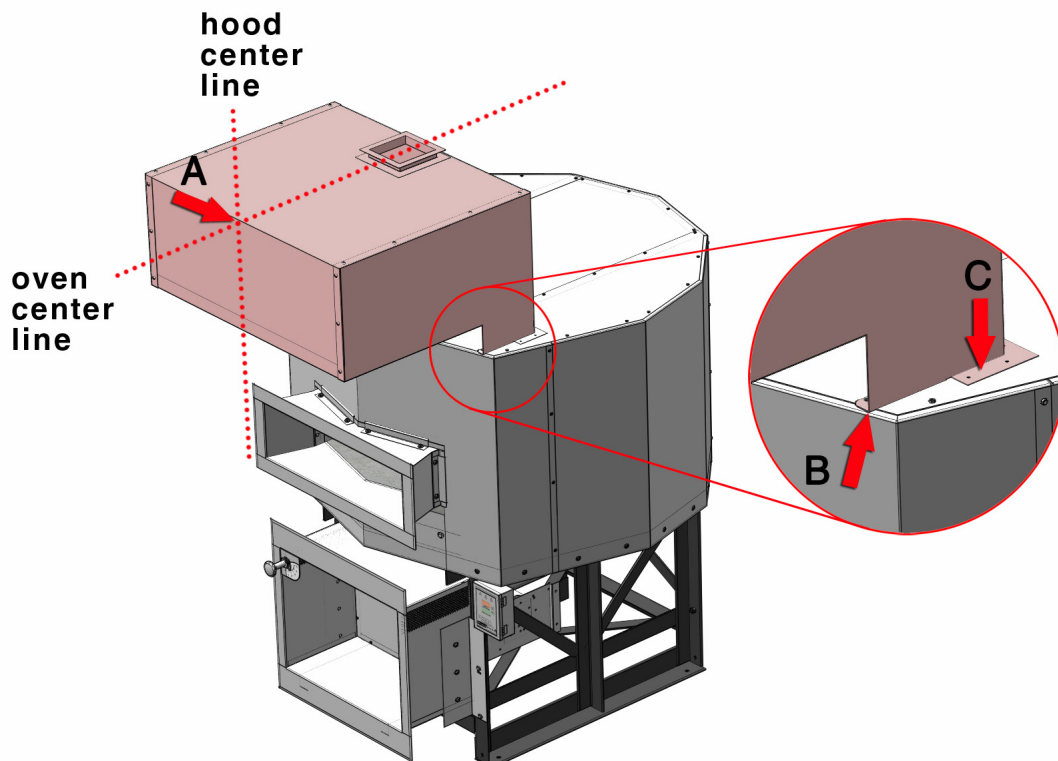



HOOD INSTALLATION WITH DECORATIVE FACADE WALL/OVEN ENCLOSURE

For installations where a hood is being used with a decorative facade wall or oven enclosure, it will be necessary to both seal the gap between the facade wall and the top of the oven, and the gaps at the sides of the hood between the facade wall and the front of the oven. This will prevent air from being pulled up the sides of the oven from below by the hood. It will also prevent debris, etc. from falling into the facade wall.

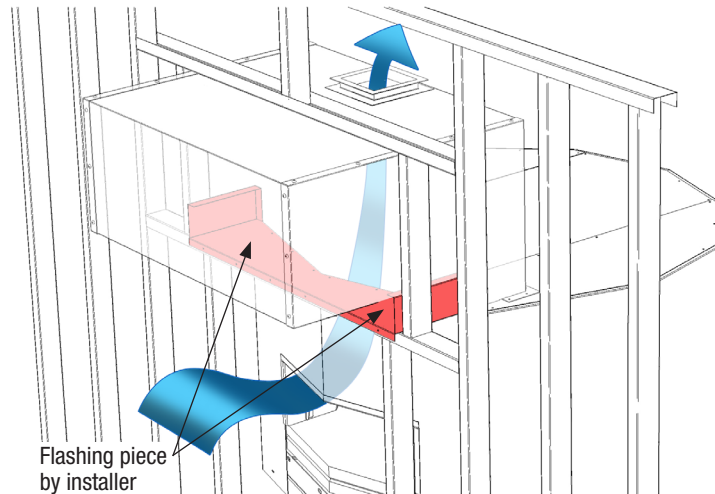

Acceptable venting

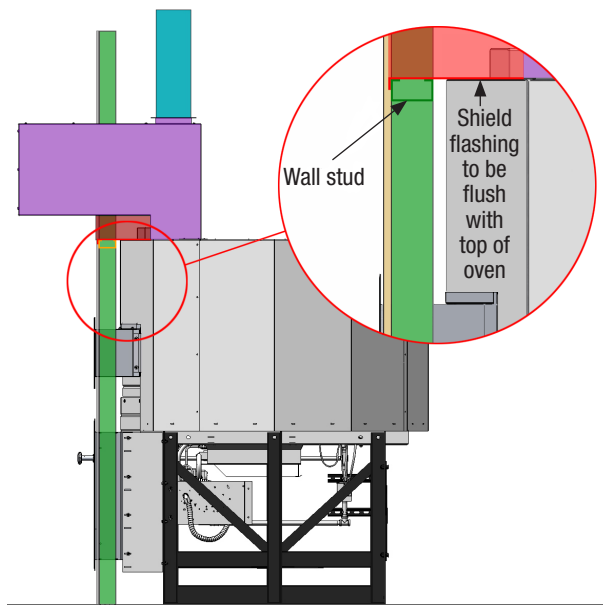

Acceptable venting

Additional flashing detail

Note that the hood extends out beyond the face of the oven. DO NOT extend the oven facade wall into the oven hood. The wall beneath the hood must stop at the top of the oven. To allow for proper function of the hood, filter removal and hood maintenance, you must provide a minimum of 8 inches of clearance between the front face of the facade wall and the front of the hood.

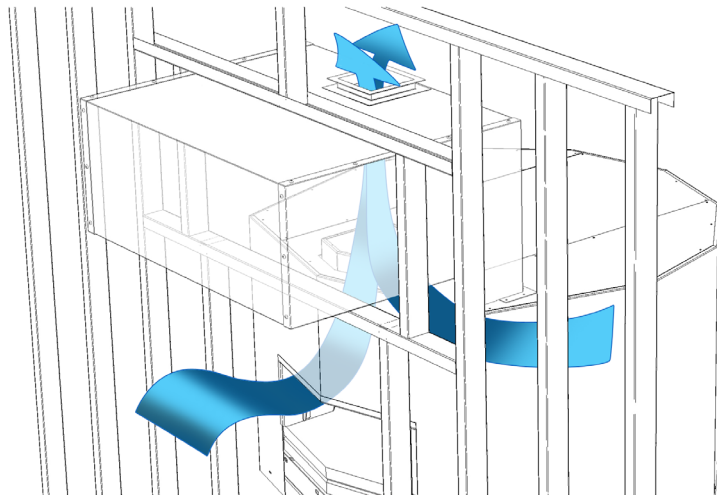

Unacceptable venting

Incorrect installation. No flashing has been installed so air being pulled up the sides of the oven from beneath.

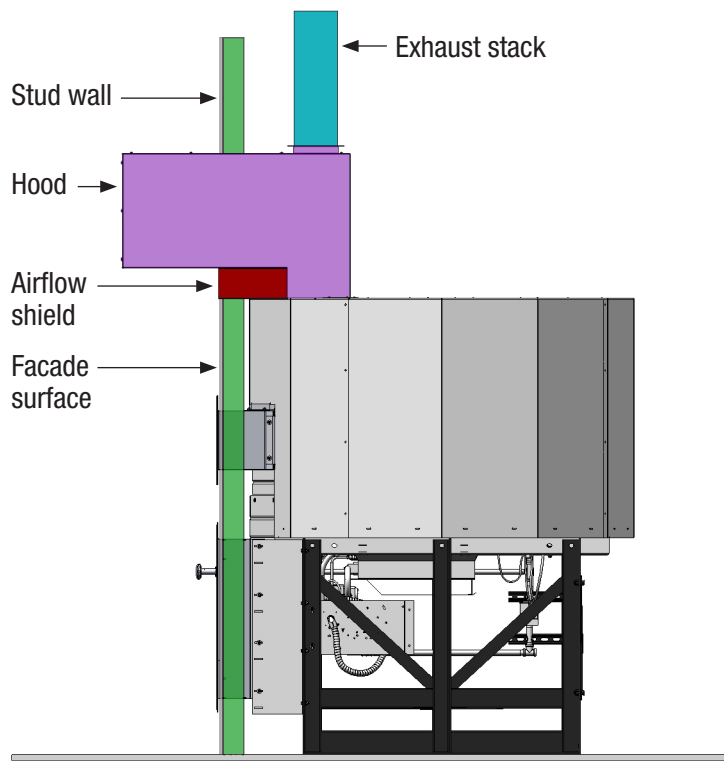

Side view of properly installed hood

Acceptable venting



CLEARANCES

The Type 1 hood requires an 18-inch clearance to combustible construction. Clearances to limited combustibles may be reduced per NFPA 96 and/or your local codes. Approved clearance reduction methods may also be used, per NFPA 96 and/or your local codes. (These reductions are applicable to the hood and/or duct only, NOT to the oven.) Consult with your local inspector regarding approved methods.

Any facade wall 6" to either side of the oven doorway and above **MUST** be of non-combustible construction with no exceptions.

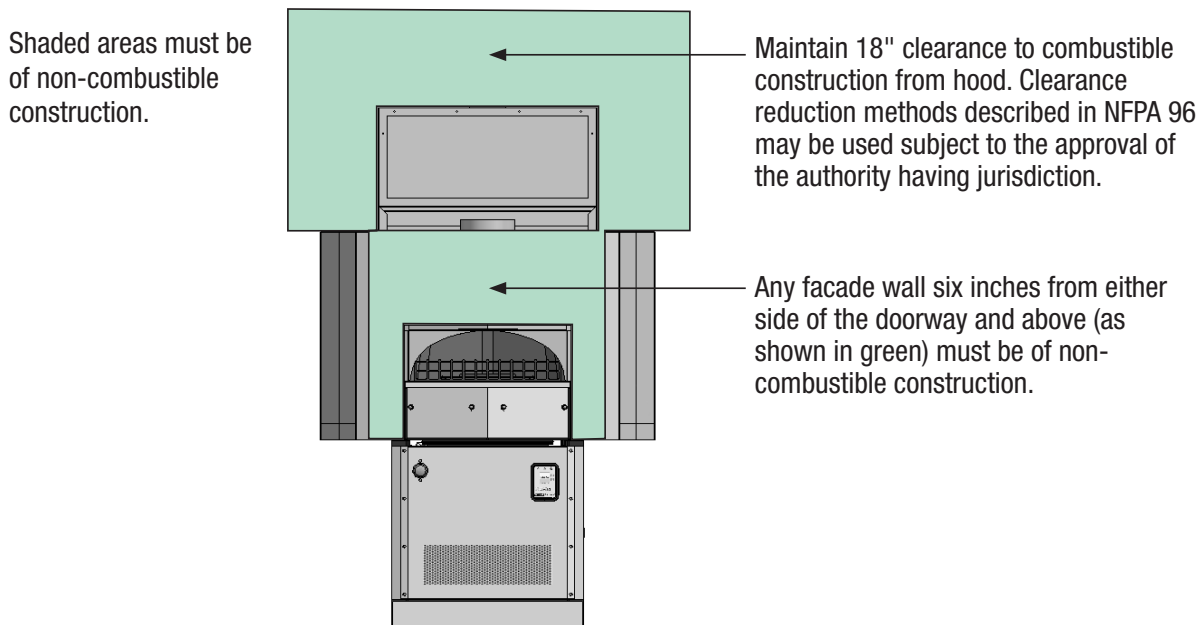

All installations subject to the approval of the local authority having jurisdiction. Wood Stone recommends you submit your venting plans in advance to your local authority for approval.



1. Mount the oven mantle (if provided) using the hardware provided. Please refer to the MANTLE MOUNTING section.
2. Mount the stainless steel Toe Kick to the front of the oven stand, angle side down using the large self tapping screws. The holes are pre-drilled in the stand. If your oven is equipped with a Service Panel extension or storage box, a Toe Kick is not necessary. Refer to assembly diagrams in the pages that immediately follow.
3. Mount the Service/Intake panel to the brackets on the front of the stand, directly below the doorway, using the screws provided. See the FRONT PANEL ASSEMBLY section. If your oven was shipped with the optional facade extensions, see EXTENSION PANEL ASSEMBLY section.

NOTE: This panel is the only access for servicing the gas and electrical components of the oven so it must be left accessible and removable. Do not obstruct the flow of combustion and ventilation air through the perforation provided on the front panel.

4. The following applies to stucco finish ovens only (models ending with “-S”): Once the oven has been set in place, cover wire mesh and metal lathing with no less than 1 inch of stucco (see STUCCO APPLICATION section for diagram and stucco formula).



The initial steps are the same for mounting either a stainless mantle or a bracket for a granite mantle.

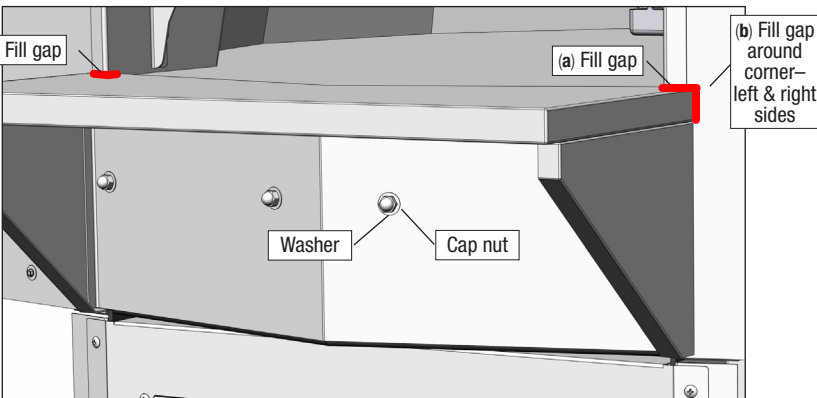
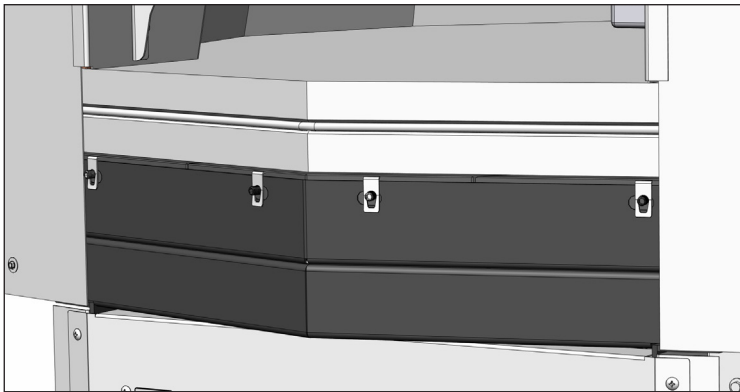

1. Begin by installing the threaded studs into the clip nuts below the oven doorway (3 or 4 turns is sufficient).
2. Position the mantle (or bracket) on the oven, making sure the rear flange rests on the floor of the oven (you may need an extra pair of hands).
Note: Do NOT remove the insulation taped to the back of the mantle.
3. Place one stainless steel washer and a cap nut onto each stud.
 Tighten the cap nuts so the mantle is securely held in place.
4. Using the high temperature silicone (provided), fill any gaps between the oven hearth and the mantle flange.
 Gaps between the mantle flange and the stainless steel doorway frame may also need to be filled with a small amount of the silicone sealant.
 Clean up any sealant before it dries.

INSTALLATION OF GRANITE

After completing the steps outlined above, apply a generous amount of silicone adhesive (provided) to the top of the steel mantle bracket.

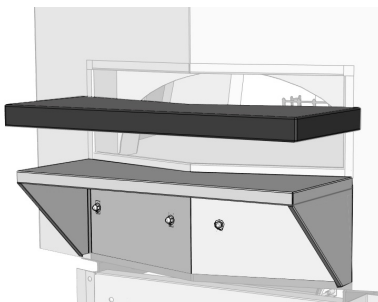

1. Put the stone in place and apply light pressure to seat it properly.
2. Make sure that the angle in the granite lines up with the angle in the bracket.
3. Allow the sealant to set for several hours, then with the provided Silicon sealant fill any gap: **(a)** between the Stone slab and the Metal bracket along the front of the Doorway, **(b)** the Stone edge & stainless steel Doorway frame and **(c)** where the Stone upper corners touch the oven.
4. Clean up any sealant before it dries.

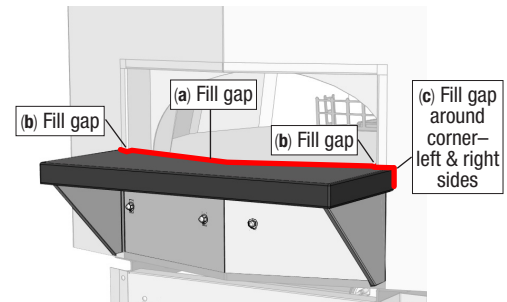



STANDARD FRONT PANEL AND TOE KICK ASSEMBLY INSTRUCTIONS

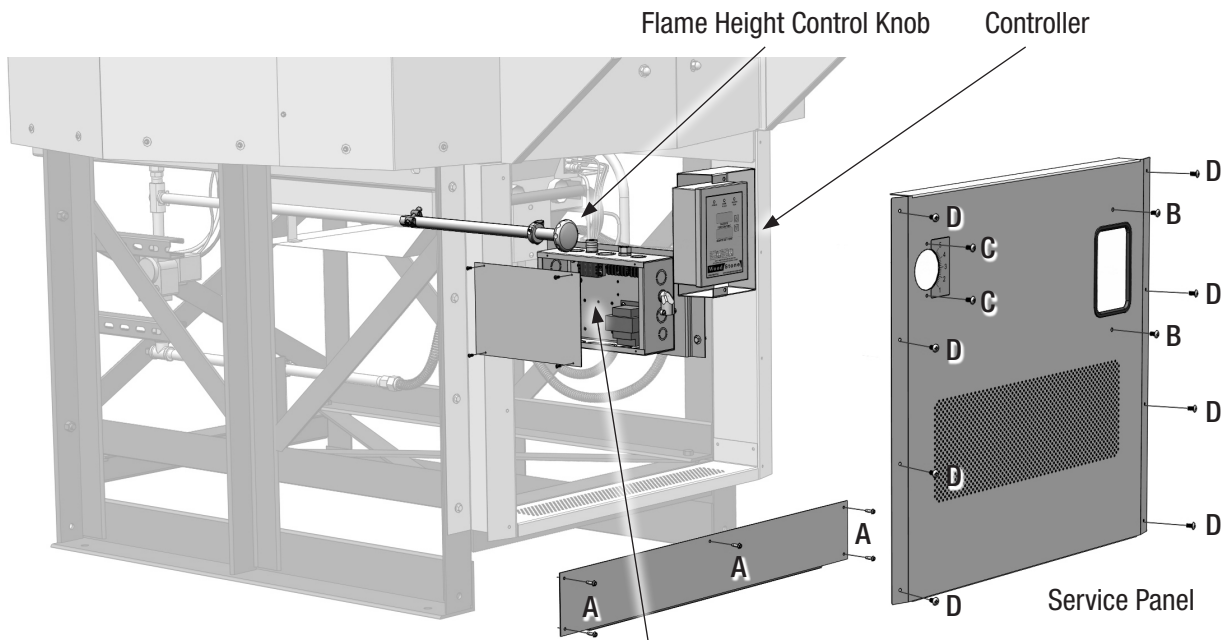

Transformer Box

Contains terminal strip for incoming power supply.

NOTE: Have licensed electrician make this electrical connection.



A Hex-head self-tapping screw. Used to attach Toe Kick. 5 total.



B Phillips head 1/4-20 screw. Used to attach Service Panel to Controller bracket. 2 total.



C Phillips head #10 screw. Used to attach Service Panel to Throttle Knob Bracket. 2 total.



D Phillips head self-tapping screw. Used to secure the sides of the Service Panel. 8 total.

SERVICE PANEL THROTTLE KNOB ASSEMBLY

The Flame Height Control Knob position can be adjusted inward or outward by loosening the Clamp and sliding the Throttle Knob Assembly to the desired position. Be sure to retighten the Clamp once the Flame Height Control Knob is in the desired position.

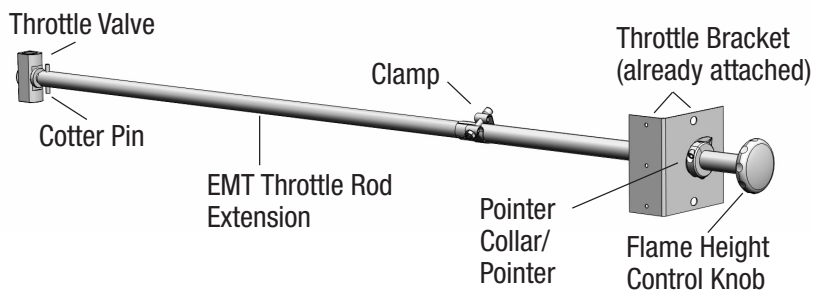



OPTIONAL LOWER EXTENSION, THROTTLE ROD AND CONTROLLER ASSEMBLY INSTRUCTIONS

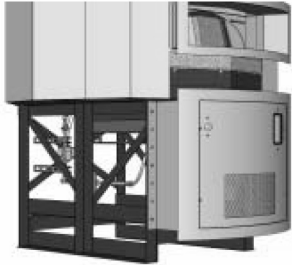

1. After the oven has been leveled, remove the Extension Panel Throttle Assembly which has been attached to the inside of the stand for shipping. Position the Lower Extension Assembly onto the front of the oven. It will rest on the guides that are welded to the oven legs. Attach the assembly to the oven legs using the supplied 1/4-20 nuts, bolts and washers.

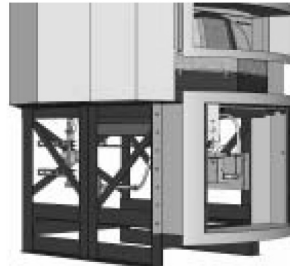

2. Remove the Front Access Panel.

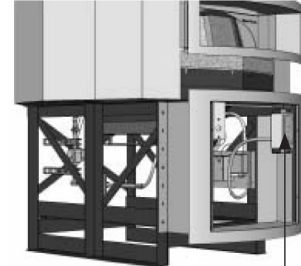

3. Attach the Controller to the Mounting Bracket (already installed) of the Extension using the 1/4-20 bolts provided.

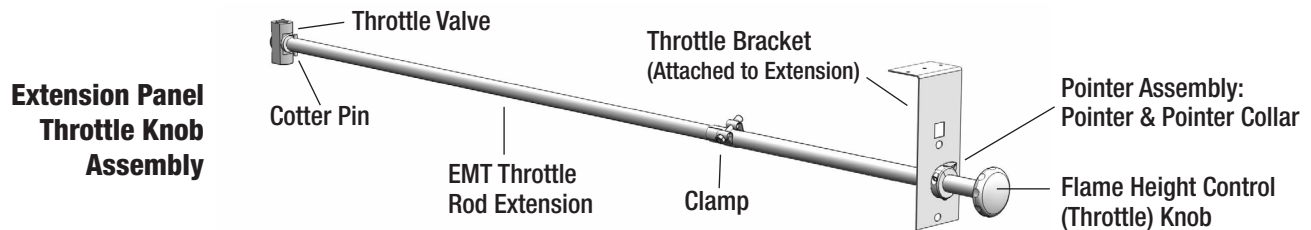

4. Remove the Flame Height Control Knob & Pointer Assembly from the Throttle Assembly. Slip the Clamp off of the Throttle Knob Assembly and slide it over the EMT Throttle Rod Extension. Slip the front of the EMT Throttle Rod through the Throttle Rod Bracket at the front of the oven, then slip the other end of the EMT onto the Throttle Valve at the back of the oven. **Note:** The end of the EMT that goes over the Throttle Valve is drilled to accept a Cotter Pin. Attach the EMT Throttle Rod Extension to the Throttle Valve using the Cotter pin and open the end of the pin slightly to prevent it from falling out. **Make certain the valve is in the full OPEN position by turning the attached Throttle Rod Extension counterclockwise until it stops.**

Continued



OPTIONAL LOWER EXTENSION, THROTTLE ROD AND CONTROLLER ASSEMBLY INSTRUCTIONS

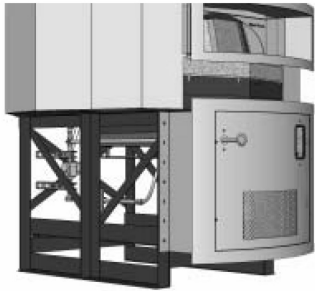

- 5.** Pass the Throttle Rod through the Throttle Bracket (already attached). Position the Pointer in approximately the 2 o'clock position. Slide the Clamp on the EMT over the end of the Throttle Rod/Knob assembly and attach the Throttle Rod to the EMT Throttle Rod Extension using the compression Clamp (5/16" nut). On curved Facade Extensions, make to leave at least 1/8" of space between the end of the Pointer and the Bracket when it is set to a horizontal position.
- 6.** Reinstall the Front Panel. Secure the Controller with a 1/4-20 screw at the top and bottom.

Use (2) #10 stainless steel sheet metal screws to secure the Front Panel to the Throttle Bracket.

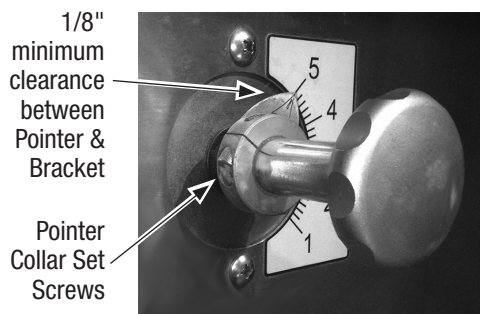

7. CALIBRATING THE POINTER

Loosen the Pointer Collar Set Screws using a 3/16" Allen wrench. Position the attached Pointer to "5" on the Flame Height Index Scale. Tighten the Pointer Collar in this position. Make certain the tip of the Pointer is at least 1/8" away from the Index Scale at the tightest point of the rotation of the Knob so it does not scrape.

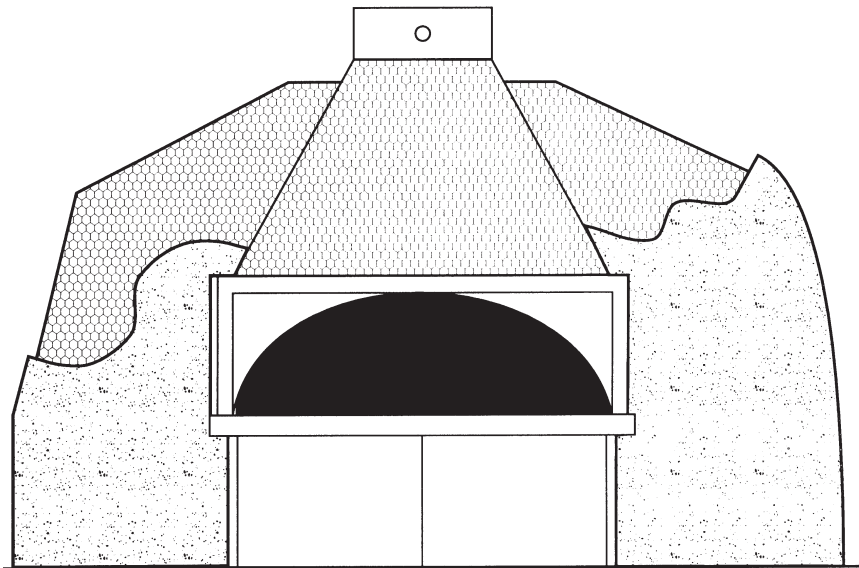

Front View

NOT TO SCALE

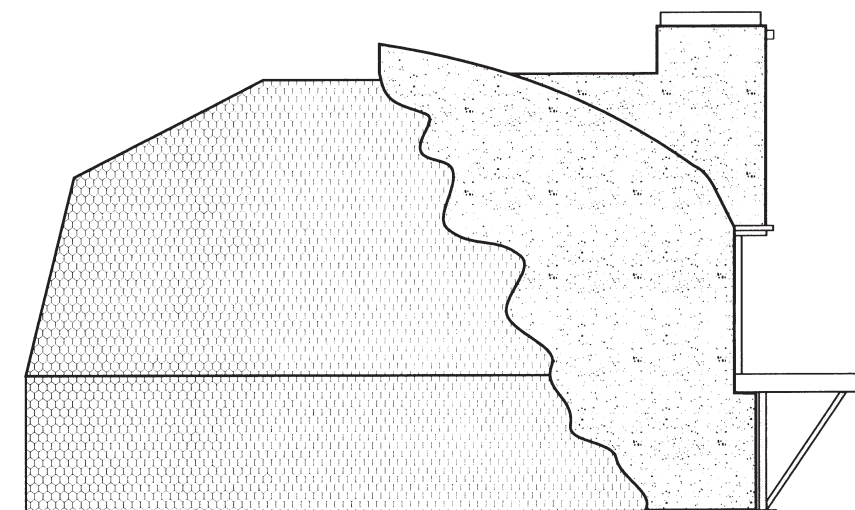

Side View

NOT TO SCALE

This figure depicts the application of stucco on a Wood Stone oven.

Use no less than one inch of stucco coating to cover all exposed metal lathing on the oven.

Maintain a minimum of 6" clearance from top and 1" from side of the appliance to all combustible surfaces.

TRADITIONAL STUCCO MIX

1 part masonry cement
1 part regular cement
5 parts sand

Stucco premix is available at your local lumber yard or building supply store.

Follow stucco manufacturer's instructions for correct mixing information.

MINIMUM STUCCO APPLICATION IS 1"



CONTROLLER FUNCTIONS

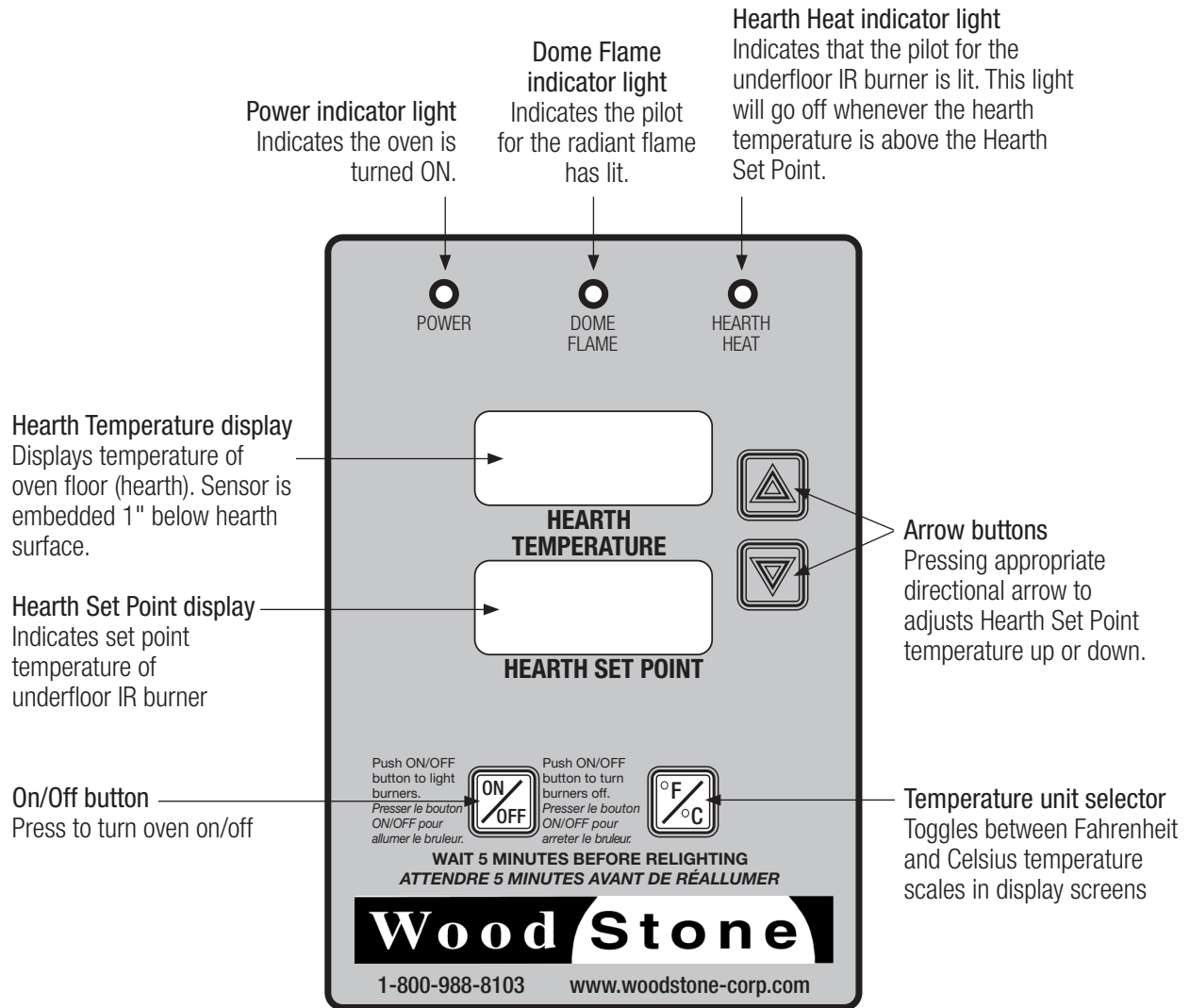



INITIAL OVEN START-UP PROCEDURE

IMPORTANT: If at any time you feel that either or both of the burners are not operating properly, turn the oven off and call for service. Before servicing, disconnect the electrical supply at the breaker and turn off the gas supply at the appliance's individual gas shutoff valve. In the event of a power failure, no attempt should be made to operate the oven.

Your oven was cured at the factory. However in the course of shipment, storage on site, etc. the ceramic materials will have absorbed moisture. It is critical that the procedure below be followed to ensure that this moisture is driven from the ceramic in a controlled fashion. This will minimize cracking and prevent damage to the oven that could otherwise occur by bringing the oven to temperature rapidly the first time it is used. This initial procedure need only be followed the first time the oven is fired and/or if the oven has not been used for an extended period of time.

BEFORE GETTING STARTED

1. Make sure main gas supply is on (valve parallel with gas line).
2. Make sure the switches on the Honeywell control gas valves are in the ON position. These are located beneath the oven.
3. Make sure that the venting system has been tested and approved for operation and is on.

FIRST DAY

1. Remove the Night Heat Retention Door(s). Push the ON/OFF button on Controller. It may take awhile for the gas to purge all the air from the gas lines.
2. Allow oven to operate at the factory settings for 1 hour (Hearth Set Point at 100 °F, radiant flame at its lowest setting). Leave the Hearth Set Point at 100 °F throughout the entire first day.
3. After one hour, raise radiant flame to 25% (~6 inch flame, "2" on the Flame Height Index Scale). Hold this setting for 4 hours.
4. After 4 hours at 25% flame, raise to 50% flame ("3" on the Flame Height Index Scale) and hold for at least another 4 hours or until the temperature reaches 500 °F.
5. Once the temperature reaches 500 °F the oven is ready for use. If you will be shutting the oven down, see the instructions that follow.

TURNING OFF THE OVEN

1. Push ON/OFF button. All gas will go off, including the pilots. Put the Night Heat Retention Door(s) in place to retain heat.

NOTE: Always wait 5 minutes before restarting the oven. **Never run the oven with the Night Heat Retention Door(s) in place.**

NOTE: Small "crazing" cracks will occur with normal heating and cooling. They will not effect the performance or durability of the oven. If cracks of 1/8" or more develop, contact Wood Stone for evaluation.



DAILY OVEN OPERATION OVERVIEW

DAILY START UP

1. Remove the Night Heat Retention Door(s).
2. Push ON/OFF button, adjust the Hearth Set Point on the Controller to the desired floor temperature. Using the Flame Height Control Knob, turn the radiant flame to its highest setting. Check your temperature after approximately one hour. If you are close to your desired temperature, reduce your flame to the holding flame setting that corresponds to your desired temperature. See the FLAME HEIGHT CONTROL section that follows to determine the proper setting that will correspond to your desired temperature. **Note:** It is only possible to program the Hearth Set Point for the underfloor IR burner to temperatures from 100–800 °F. Once proper temperatures for your application have been established, there should be little or no need to change the Hearth Set Point. The Hearth Temperature readout will display “LO” until the oven floor reaches 100 °F.

ADJUSTING THE RADIANT (DOME) FLAME

To adjust the radiant flame: The radiant flame is always on (when the oven is operating) and can be adjusted to any flame intensity between its highest and lowest setting. Simply turn the Flame Height Control Knob located to the lower left of the doorway, beneath the mantle. **This burner is the primary heat source for the oven.** The underfloor IR burner acts as an assist, to maintain desired floor temperatures during periods of high food production.

TURNING OFF THE OVEN

1. Push the ON/OFF button. All gas will go off, including the pilots.
2. Put the Night Heat Retention Door(s) in place to retain heat.

Note: Always wait 5 minutes before restarting the oven. **Never run the oven with the Night Heat Retention Door(s) in place.**

DURING THE FIRST FEW DAYS OF OPERATION, SMALL AMOUNTS OF WATER MAY APPEAR DRIPPING FROM THE OVEN. THIS IS NORMAL AND WILL STOP WITHIN A FEW DAYS.

NIGHT HEAT RETENTION DOORS

NOTE: Never operate this oven with the stainless steel Night Heat Retention Doors in place. This option is for heat retention **only**, and should only be used when the oven is turned OFF.

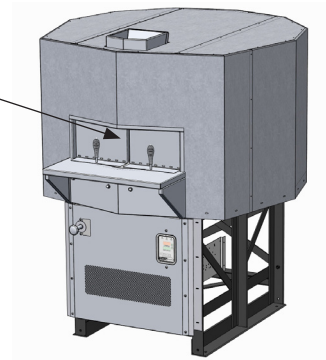



DETERMINING THE APPROPRIATE FLAME HEIGHT

For each specific configuration of oven there is a system that determines what the desired flame height will be. Each flame height corresponds to a saturated floor temperature. Several factors need to be accounted for in order to determine this relationship for each oven. Burning wood simultaneously in the oven will influence the settings below.

USING THE FLAME HEIGHT INDICATOR SCALE

Heat Up Flame: Set Throttle Knob Pointer at "5" (highest setting) on the Flame Height Index Scale until desired temperature is reached.

Holding Flame: Set the flame height to "3" (~8–9" flame) on the Flame Height Index Scale for desired temperature of 570–600 °F. Set the flame height to "2" (~5–6" flame) on the Flame Height Index Scale for desired temperature of 450–480 °F.

Cooking Flame: After introducing the pizza/product into the oven, visually raise the flame to approximately 3 inches higher than the Holding Flame.

Return the Flame Height Control Knob to the Holding Flame position after removing the pizza/product from the oven.

THE COOKING FLAME HAS TWO PURPOSES:

1. To bake the top of the pizza/product as fast as the bottom of the pizza/product.
2. To help replace heat to the floor (hearth) that is lost during production cooking.

Note: The settings recommended on the Flame Height Index Scale for specific flames are based on ovens that have been installed according to specifications. Individual results may vary slightly.

FLAME HEIGHT INDICATOR

Comprised of two parts

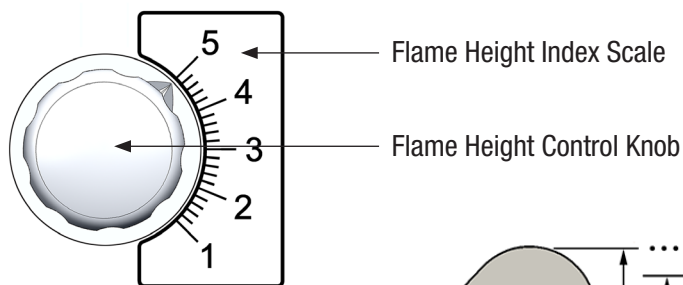

For more information regarding Flame Height Control, go to the Resource Center section of our web site at:
www.woodstone-corp.com

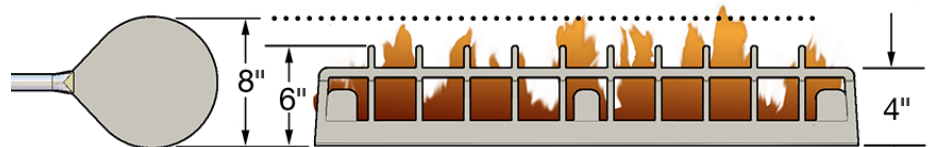

TIP: You can visually estimate flame heights using the Wood Stone utility peel, which is 8" tall when standing on edge in front of the flame. Then relate height to the corresponding number on the Flame Height Index Scale.

**CLEANING THE OVEN**

Clean as needed—multiple times per hour depending on production. Wood Stone recommends the use of long-handled brushes for sweeping up surface debris that will accumulate on the floor of the oven during use. Use a natural fiber brush, always brushing away from the radiant burner well to the doorway where it can be easily removed with a dough cutter or spatula. For deeper cleaning, use a brass bristled brush. The oven floor can be then cleaned with a damp (not wet) rag wrapped around the brush head.

Wood Stone offers an assortment of oven brushes available through your dealer. Specification sheets may be viewed on the Wood Stone website under Tools & Accessories.

NEVER PLACE ANYTHING IN OR ABOVE THE RADIANT FLAME.

NEVER SWEEP DEBRIS INTO THE RADIANT BURNER. THIS CAN CAUSE THE BURNER TO CUT OUT, DAMAGE BURNER COMPONENTS, AND/OR EFFECT BURNER PERFORMANCE. PROBLEMS CAUSED BY DEBRIS IN THE RADIANT BURNER WILL NOT BE COVERED BY THE OVEN WARRANTY.

NEVER USE ICE, EXCESSIVE WATER, ANY LIQUID, OR ANY TYPE OF CLEANING CHEMICAL ON THE OVEN FLOOR. DOING SO CAN SEVERELY DAMAGE THE OVEN CERAMIC AND THIS DAMAGE WILL NOT BE COVERED UNDER WARRANTY

ESTABLISHING A THERMAL CLEANING SCHEDULE

Wood Stone ovens are typically operated at temperatures which preclude the need for cleaning of the interior walls and ceiling (the dome) of the oven. If, however, you routinely operate the oven at floor temperatures lower than 450 °F, you may notice a buildup on the interior walls and/or ceiling of the oven. If this is the case, use the following procedure to periodically clean the oven. The frequency of thermal cleaning will be determined by the amount of buildup experienced.

THERMAL CLEANING

If a Wood Stone gas-fired oven is operated at low temperatures (below 450 °F), it is possible that grease from food could condense on the walls and ceiling of the oven. To remove the grease that has accumulated on the walls and ceiling of the oven, simply turn the radiant flame to its highest setting. Monitor the floor temperature displayed on the Controller. When the floor reaches 600 °F, lower the flame slightly so as to maintain the oven floor temperature near 600 °F for about an hour. Once the oven dome appears clean, allow the oven to return to normal operating temperatures and continue normal operation.



WS-MS-RFG-W and RFG-IR-W models are approved to allow the burning of wood in the cooking chamber in addition to the gas burners. When burning wood, the fire should be placed to one side of the oven chamber, as close to the door opening as is possible (this is often described as the 8 o'clock or 4 o'clock position). Burn a maximum of 15 lbs. of wood per hour. **If flames spill out of the doorway, or the oven temperature exceeds 850 °F, you are over firing the oven.**

Make every effort to keep ash and other debris out of the radiant burner well. Do not use the radiant burner as a "backstop" when shoveling ash and/or coals out of the oven. **Burner problems resulting from debris or ash in the burner well will not be covered by the oven warranty.** Using the oven floor brush and ash shovel, move debris only toward the oven doorway and dispose of safely.

NOTE: Ovens burning solid fuel require a more frequent maintenance schedule. Call with questions regarding maintenance frequency.

See the FUELWOOD FACTS section later this manual for more information on burning wood.

Wood should be stored and handled in accordance with the recommendations outlined in NFPA 96.

The interior floor and dome of the oven do not require creosote or soot removal. The oven flue and exhaust system will require inspection and cleaning. The exhaust system must be inspected and cleaned per the manufacturer's and or local code official's recommendations. **Wood Stone recommends cleaning and inspection at least monthly on any ventilation system serving solid fuel equipment.**

DISPOSE OF ASH PER THE FOLLOWING:

1. Place ashes into a metal container with a tight fitting lid.
2. Place the closed container of ashes on a non-combustible floor or on the ground.
3. Place the closed container of ashes well away from all combustible materials, pending final disposal.
4. Retain the ashes in the closed container until all the cinders have thoroughly cooled. Ashes can then be disposed of safely.

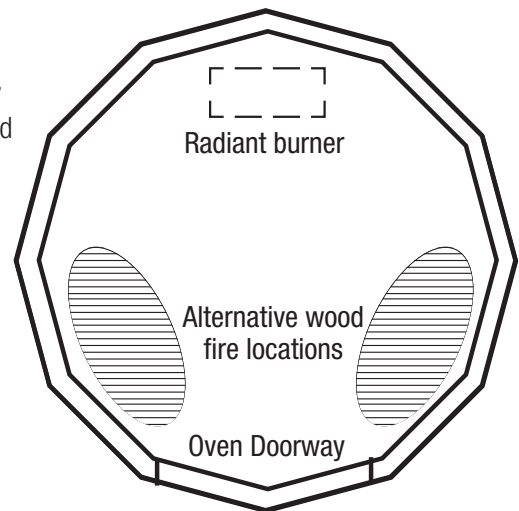

Wood Stone's stainless steel ash shovel and double compartment ash disposal system offer a safe and convenient way to dispose of ash. Specification sheets may be viewed on the Wood Stone website under Tools & Accessories



STARTING THE FIRE

Build a small kindling fire of 5–7 lbs. of heavy, hardwood. We suggest using a fire starter (paraffin/sawdust stick) to start the fire. Begin with (3) small pieces of wood (about 1–3" diameter and 14–16" in length). The fire should be located on side of the oven chamber opposite the radiant gas burner. The fire may be burned at the back of the oven at the center provided the coal bed is kept at least 12 inches away from the Radiant Burner. Wood may be burned at a rate not to exceed 15 lbs. per hour.

Use only seasoned hardwoods with a moisture content of 20% or less. Use of soft woods, such as pine, cedar, hemlock etc., and wet or "green" wood, will cause a build-up of residue throughout the exhaust system. (See the FUELWOOD FACTS section later in this manual, or consult factory for information on what types of wood can be used for oven fuel.)

The fire should be ignited a couple of hours before the oven needs to be at cooking temperature. Once the oven is being used daily, the fire can be ignited using still glowing coals from the previous day's fire.

The oven is heated more evenly and effectively by the fire positioned on the side rather than in the rear of the oven. Adding about 5–7 lbs. of wood per hour should bring the oven temperature up about 100 °F per hour (this will vary slightly depending on the type and moisture content of the wood and the size of the oven).

The floor temperature is indicated by the Digital Hearth Temperature Readout and should not exceed 850 °F. Once the desired temperature is reached, maintain it by the addition of wood as needed. Do not toss or throw wood against back or side walls of oven—this may void the warranty. At the end of the work day, put removable Night Heat Retention Door(s) into door opening to hold heat in the oven overnight.

DO NOT OVER-FIRE THIS OVEN. IF FLAMES ARE SPILLING OUT OF THE DOOR OPENING, OR IF OVEN FLOOR TEMPERATURE EXCEEDS 850 °F, THEN YOU ARE OVER-FIRING THE OVEN.

MANAGING THE FIRE / TEMPERATURE

These suggestions will normally produce an oven floor temperature of 500–600 °F. If you need to achieve higher temperatures, use a little more wood. For lower temperatures, use a little less wood.

MS-4 oven: Maintain temperature using 1 log with 6–10" of open flame working on the coal bed.

MS-5 & MS-6 ovens: Maintain temperature using 1–1½ logs with 8–12" of open flame working on the coal bed.

MS-7 oven: Maintain temperature using 1½–2 logs with 8–14" of open flame working on the coal bed.

IMPORTANT NOTES

- One pound of properly cured, heavy, hardwood produces the potential of 6,500 BTU/hr.
- The temperature sensor (thermocouple) is located at the center of the floor, one inch under the surface. The thermocouple will give false readings if the fire is placed on top of it.
- If at anytime the oven is allowed to cool to room temperature for an extended period of time, this heat-up procedure will need to be repeated to avoid thermal shocking of the refractory stone which can cause excessive cracking.

DO NOT POUR OR SPRAY LIQUIDS ONTO THE OVEN DECK OR INTO THE OVEN INTERIOR AS THIS CAN DAMAGE THE CERAMIC AND WILL VOID THE WARRANTY.



REMOVAL OF CREOSOTE AND SOOT

As with all commercial cooking equipment exhaust systems, a regular inspection and cleaning schedule is needed to prevent the possibility of a hood or duct fire. The frequency of inspection and cleaning will depend on hours of use and type and quality of wood used as fuel. Only use hardwood species dried to a moisture content of 20% or less. See the FUELWOOD FACTS section at the end of this manual.

When wood is burned slowly, it produces tar and other organic vapors, which combine with expelled moisture to form creosote. The creosote vapors condense in the relatively cool oven flue of a slow-burning fire. As a result, creosote residue accumulates in the duct. When ignited, this creosote makes an extremely hot fire.

The duct serving this oven should be inspected at least twice a month during the first two months of operation to establish rate of creosote buildup and necessary cleaning schedule. If creosote or soot has accumulated, it should be removed to reduce the risk of a flue fire. Typically we recommend cleaning the duct system at least monthly for all solid fuel equipment.

The interior floor and dome of the oven do not require creosote or soot removal. The oven flue and exhaust system will require inspection and cleaning. The exhaust system should be inspected and cleaned per the manufacturer's and or local code official's recommendations. Wood Stone recommends cleaning and inspection at least monthly on any ventilation system serving solid fuel equipment.

DISPOSE OF ASH PER THE FOLLOWING:

1. Place ashes into a metal container with a tight fitting lid.
2. Place the closed container of ashes on a non-combustible floor or on the ground.
3. Place the closed container of ashes well away from all combustible materials, pending final disposal.
4. Retain the ashes in the closed container until all the cinders have thoroughly cooled. Ashes can then be disposed of safely.



Wood Stone's stainless steel ash shovel and double compartment ash disposal system offer a safe and convenient way to dispose of ash. Specification sheets may be viewed on the Wood Stone website under Tools & Accessories.



WHAT TYPE OF WOOD SHOULD YOU USE TO FIRE YOUR SOLID FUEL COOKING EQUIPMENT?

The answer to this question depends on several considerations: geographical location, availability and relative cost of various fuelwood species and individual preferences regarding the flavor qualities of various wood types. There are a wide variety of good fuelwood species in all geographic locations. Each species of wood has different characteristics. The table below should help weigh the pros and cons of various types of wood. Wood from conifers (pine trees) is not recommended due to its poor fuelwood characteristics (low weight, low-med heat, poor coaling, high sparking and high residual creosote).

Wood Type	Heat	Lb/Cord	Lighting	Coaling	Sparks	Fragrance*
Alder	Med-Low	2500	Fair	Good	Moderate	Slight
Apple	High-Med	4400	Fair	Excellent	Few	Excellent
Ash	High	3500	Fairly Difficult	Good-Excellent	Few	Slight
Beech	High	3800	Difficult	Excellent	Few	Good
Birch (white)	Medium	3000	Easy	Good	Moderate	Slight
Cherry	Medium	2000	Fair	Excellent	Few	Excellent
Elm	High	2300	Very Difficult	Good	Very Few	Fair
Hickory	Very High	4200	Fairly Difficult	Excellent	Moderate	Excellent
Maple (red)	High-Med	3200	Fairly Difficult	Excellent	Few	Good
Maple (sugar)	High	3700	Difficult	Excellent	Few	Good
Mesquite	Very High		Very Difficult	Excellent	Many	Excellent
Oak (live)	Very High	4600	Very Difficult	Excellent	Few	Fair
Oak (red)	High	3700	Difficult	Excellent	Few	Fair
Oak (white)	Very High	4200	Fairly Difficult	Excellent	Few	Fair
Pecan	High		Fair	Good	Few	Good

*The desirability of various fragrances is largely a matter of personal preference.

Whichever type of wood you use, **MAKE SURE YOU KNOW THE MOISTURE CONTENT.** Properly seasoned wood contains 20% moisture or less. If wood contains more than 20% moisture, it should not be accepted for use. Wood should be stored off the ground and out of the rain in an environment that allows good air circulation so that the drying process can continue. Wet wood is the most common operational difficulty associated with wood-fired cooking equipment. Wood Stone's optional Mini-Ligno E Wood Moisture Meter can save you from paying for water when you thought you were paying for wood (see the Tools & Accessories section of woodstone-corp.com).

Calculate your approximate monthly, daily and hourly fuel-wood costs using the following formulas:
The cost of well-seasoned hardwood varies greatly with geographical location.

$$\text{Cost per month} = A \times C \quad \text{Cost per day} = \frac{A \times C}{30} \quad \text{Cost per hour} = \frac{\left(\frac{A \times C}{30}\right)}{12 \text{ hr day}}$$

A = Cost/cord (from wood supplier)

B = lb/cord (from above table)

C = Cords/mth (from experience, or call Wood Stone for an estimate)

When burned, a pound of any wood releases approximately 6500 BTU/hr, so it is better to compare the price of wood by the pound rather than by the cord. A full cord of wood measures 4' x 4' x 8' when stacked.

$$\text{Cost per lb} = \frac{A}{B}$$

Do not use pressed wood products in Wood Stone food service equipment, they may damage the ceramics.



PROBLEM	CAUSE/SOLUTION
Controller will not turn on	<ol style="list-style-type: none"> Incoming power to oven turned off. Check circuit breaker for circuit supplying the oven. Check that any wall switches external to the oven that control oven power are turned on. Check that any interlocks external to the oven are turned on. If Controller still does not turn on, please contact Wood Stone for assistance.
Radiant flame does not light	<ol style="list-style-type: none"> Is gas turned on to the oven? Is gas shut-off valve turned all the way on? Debris in burner. Burner may require cleaning. Contact Wood Stone for assistance. Damaged igniter or gas valve. Contact Wood Stone for assistance. If the oven is being started for the first time: Has all air been bled from the gas line? Is the switch on the SV-2 valve in the ON position? NOTE: Valve is located beneath the oven at the rear, towards the side where the radiant burner is located.
Underfloor burner is not running. “Hearth Heat” light is off.	Hearth temperature is above the Hearth Set Point.
Hearth Temperature is above the Hearth Set Point.	This is normal. Radiant (dome) flame can drive the temperature over the Hearth Set Point. The Hearth Set Point only controls the Underfloor IR burner. Turn down the dome flame if needed.
“Chec” display on Controller	Underfloor IR burner did not fire when the floor temperature dropped below the Hearth Set Point. Contact Wood Stone for assistance.
Flame cuts out	<ol style="list-style-type: none"> Debris in burner. Oven is being run with the Night Heat Retention Door in place. Door must be removed whenever the oven is turned on. Wind blowing into the oven, or other venting issue.

Please contact Wood Stone at 1-800-988-8103 should service be necessary, or if you have any questions about your oven. Our normal service hours are Mon.–Fri., 8am–5pm Pacific time. If calling after hours, follow the recorded instructions for emergency service and a Wood Stone technician will get back to you promptly.



BURNER OPERATION SEQUENCE RFG-IR-(W) OVEN - TYPE 2 CONTROLLER

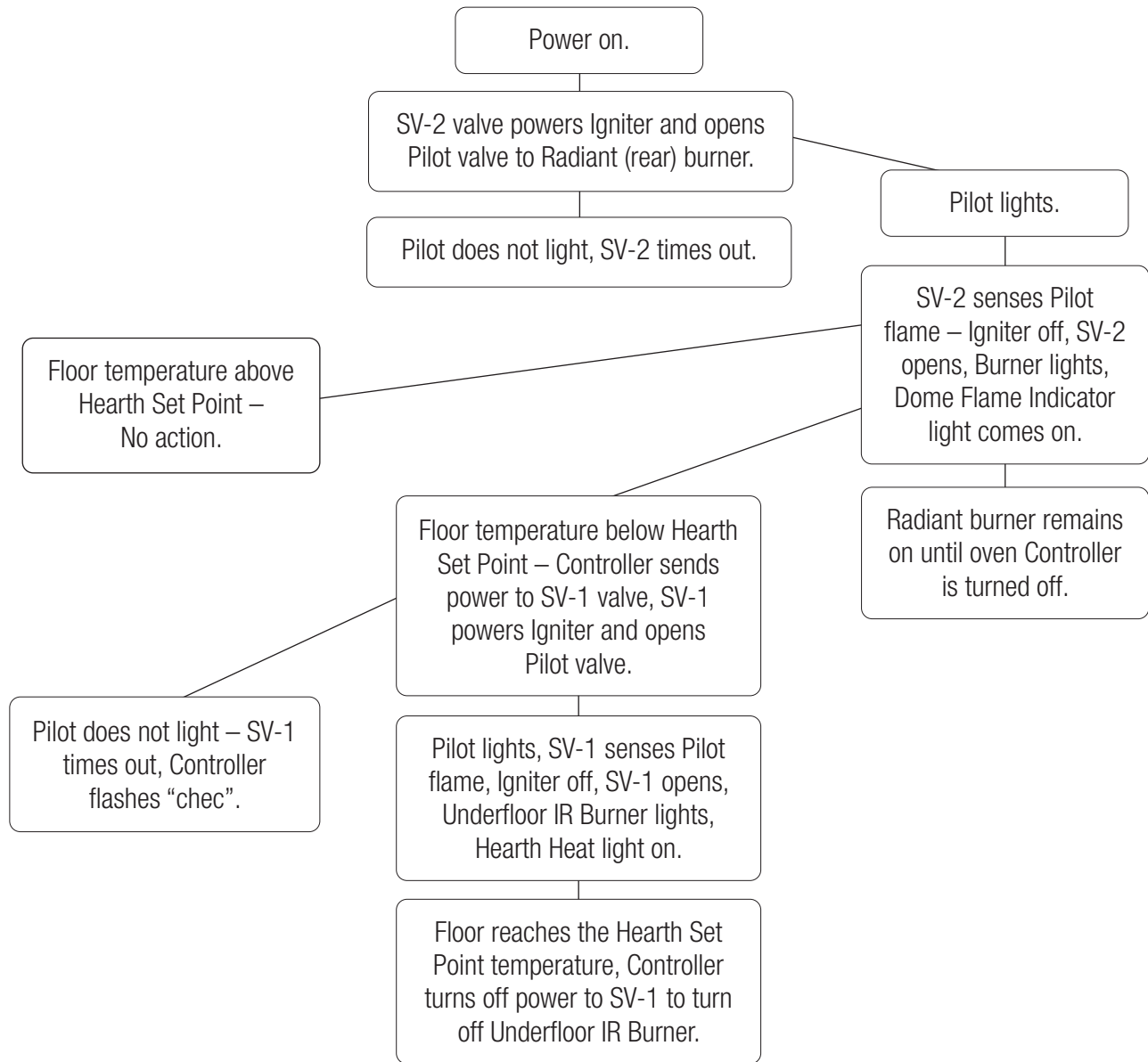



RFG-IR-W 120 VAC MODELS

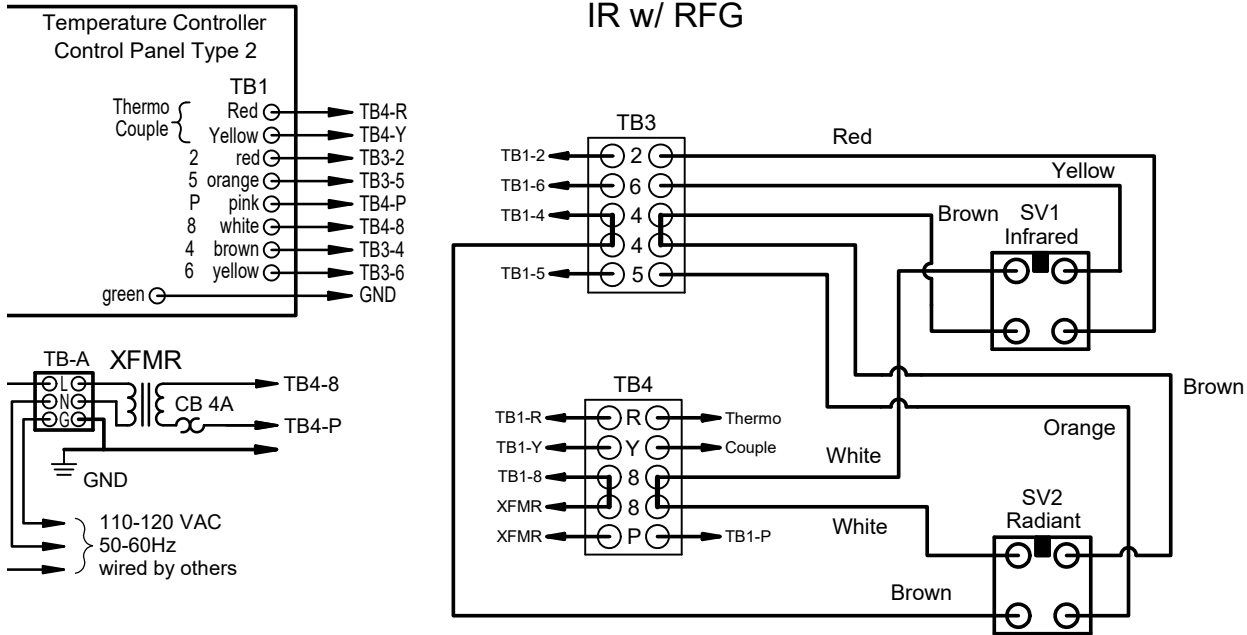



RFG-IR-W 240 VAC MODELS

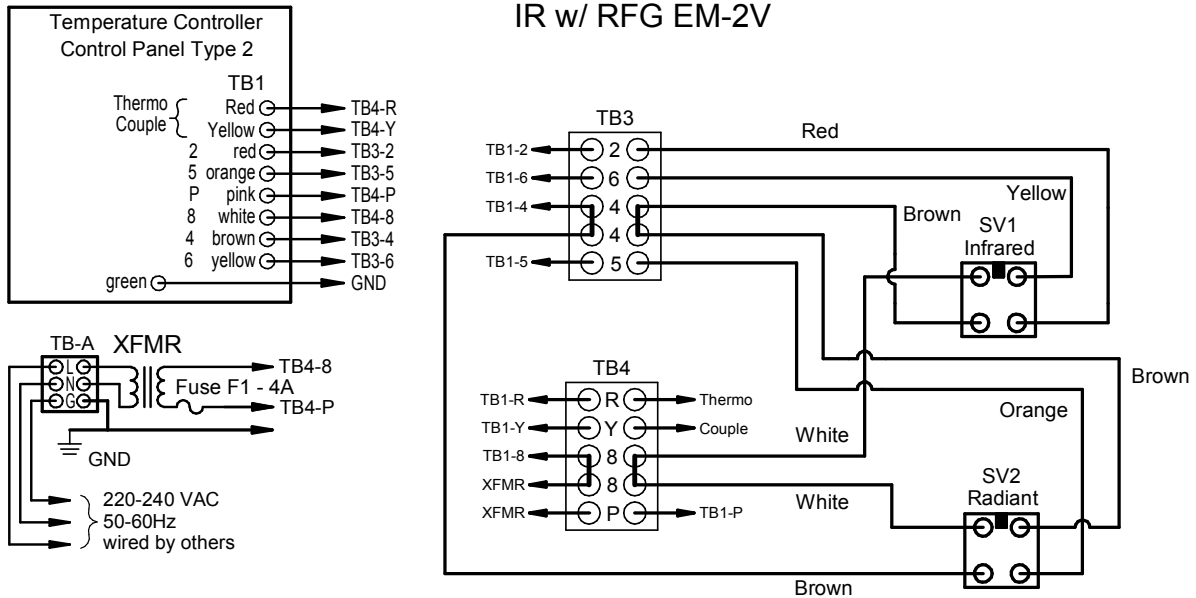



INTERLOCK OF OVEN CONTROL TO AN EXHAUST FAN

This connection is intended to interrupt power to the oven until the fan is turned on.

This connection is NOT to be used with ovens burning solid fuel.

**The ventilation system must be running any time there is solid fuel burning in the oven.
Failure to follow this instruction can lead to a fire, as well as dangerous buildup of combustion byproducts, including Carbon Monoxide.**

Wired by others

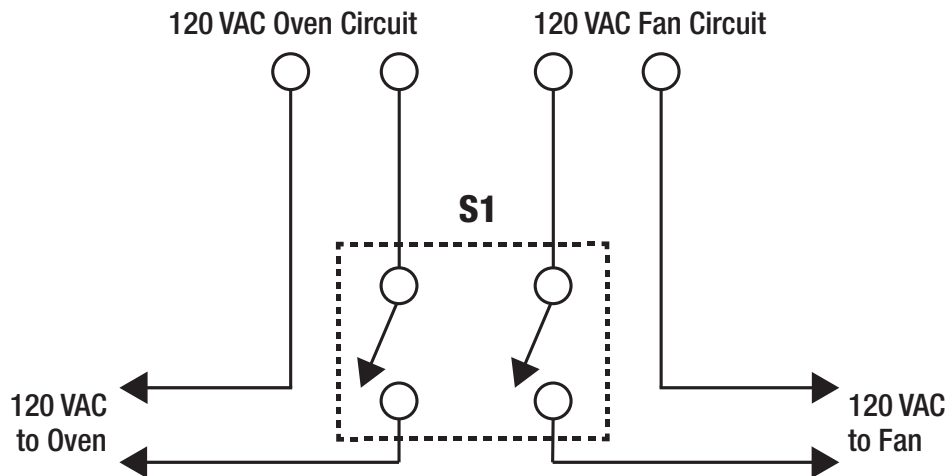

S1 is a Double Pole, Single Throw (DPST) switch provided by others.

S1 is a double pole, single throw switch (provided by others) that interrupts in-coming power to both the oven and the fan. The intent is to prevent the operation of the oven's gas burner in the event the fan is shut off.

Any interruption of the power to the oven will cause the oven (including all burners and pilots) to shut off, and it will be necessary to restart the oven by pressing the start switch once power is restored.

For additional interlock options, see the Wood Stone Interlock Options supplement in the Manuals section on the website, woodstone-corp.com, or contact Wood Stone for additional information.



ALL WARRANTY SERVICE MUST BE PRE-APPROVED BY WOOD STONE

Wood Stone warrants its equipment to the original purchaser against defects in material or manufacture for a period of one year from the original date of purchase, subject to the following exclusions and limitations.

Please contact the factory first at 1.800.988.8103 or 1.360.650.1111, seven days a week. Our normal business hours are 8am to 5pm Pacific time Monday–Friday. If calling during non-business hours, follow the recorded instructions for emergency service and a Wood Stone technician will get back to you promptly.

EXCLUSIONS

The warranties provided by Wood Stone do not apply in the following instances:

1. In the event that the equipment is improperly installed. Proper installation is the responsibility of the installer; proper installation procedures are prescribed by the Wood Stone installation and operation manual.
2. In the event the equipment is improperly or inadequately maintained. Proper maintenance is the responsibility of the user; proper maintenance procedures are prescribed in the Wood Stone Installation and Operation Manual. Burner problems resulting from debris or ash in the burner well will not be covered by the warranty. Call with questions regarding maintenance frequency.
3. In the event that the failure or malfunction of the appliance or any part thereof is caused by abnormal or improper use or is otherwise not attributable to defect in material or manufacture.
4. In the event that the appliance, by whatever cause, has been materially altered from the condition in which it left the factory.
5. In the event that the rating plate has been removed, altered or obliterated.
6. On parts that would be normally worn or replaced under normal conditions.
7. Normal cracking due to expansion and contraction stress relief in the ceramic firebox.

8. In the event that pressed log products of any type have been burned in the equipment.

9. Damage resulting from the use of chemical cleaning products in the oven, as well as any damage from liquids or chemicals, including water, being poured or sprayed into the oven.

If any oral statements have been made regarding this appliance, such statements do not constitute warranties and are not part of the contract of sale. This Limited Warranty constitutes the complete, final and exclusive statement with regard to warranties.

THIS LIMITED WARRANTY IS EXCLUSIVE AND IN LIEU OF ALL OTHER WARRANTIES WHETHER WRITTEN, ORAL OR IMPLIED, INCLUDING, BUT NOT LIMITED TO, ANY WARRANTY OF MERCHANTABILITY OR FITNESS FOR PARTICULAR PURPOSE OR WARRANTY AGAINST LATENT DEFECTS

LIMITATIONS OF LIABILITY

In the event of warranty claim or otherwise, the sole obligation of Wood Stone shall be the repair and/or replacement, at the option of Wood Stone, of the appliance or component or part thereof. Such repair or replacement shall be at the expense of Wood Stone with the exception of travel over 100 miles or two hours, overtime, and holiday charges which shall be at the expense of the purchaser. Any repair or replacement under this warranty does not constitute an extension of the original warranty for any period of the appliance or for any component or part thereof. Parts to be replaced under this warranty will be repaired or replaced at the option of Wood Stone with new or functionally operative parts. The liability of Wood Stone on any claim of any kind, including claims based on warranty, expressed or implied, contract, negligence, strict liability or any other theories shall be solely and exclusively the repair or replacement of the product as stated herein, and such liability shall not include, and purchaser specifically renounces any rights to recover, special, incidental, consequential or other damages of any kind whatsoever, including, but not limited to, injuries to persons or damage to property, loss of profits or anticipated profits, or loss of use of the product.

TO SECURE WARRANTY SERVICE

If you claim a defect covered by this Limited Warranty, contact:

Wood Stone Corporation, Attn: Service Department, 1801 W. Bakerview Rd., Bellingham, WA 98226 USA



WOOD STONE CORPORATION

1801 W. Bakerview Rd.
Bellingham, WA 98226 USA

Toll Free 800.988.8103

Tel 360.650.1111

Fax 360.650.1166

www.woodstone-corp.com

An ongoing program of product improvement may require us to change specifications without notice.